

# Drives

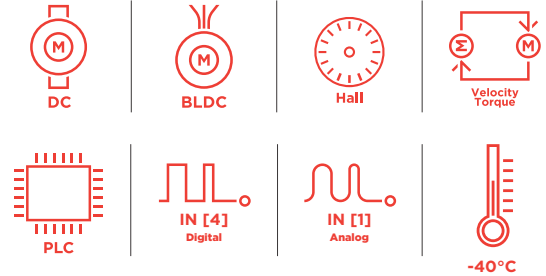

# SVTE-A-B40-CanOpen Servo Drives

60VDC | 10A  
DC motors, BLDC motors

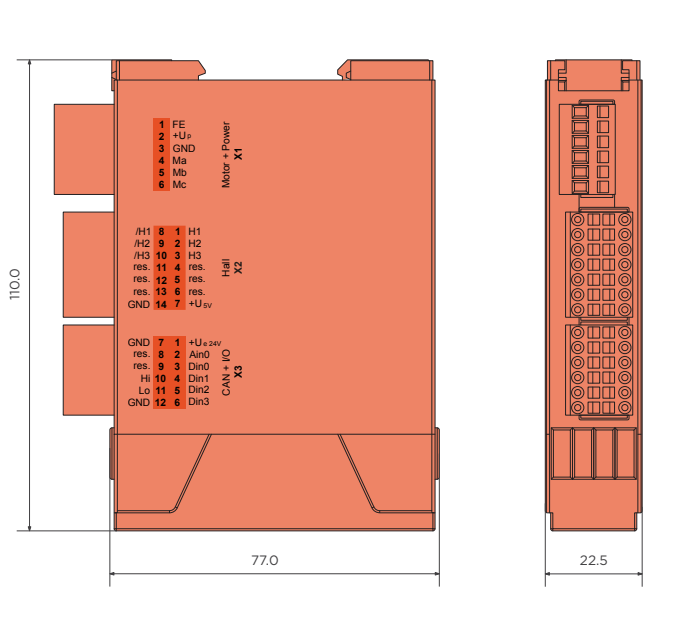

CANopen

Values	Unit
<b>Power</b>	
1 Electronic supply voltage U <sub>e</sub>	VDC 9..30
2 Power supply voltage U <sub>p</sub>	VDC 9..60
3 Max. output current	A 30
4 Continuous output current @ U <sub>p</sub> =24VDC	A 10
5 Continuous output current @ U <sub>p</sub> =48VDC	A 8.5
6 Output voltage	Up to 90%
<b>Motor types</b>	
7 DC motors	yes
8 BLDC motors	yes
9 Stepper motors	no
<b>Mechanical</b>	
10 Size LxWxH	mm 110 x 22.5 x 77
<b>CAN bus</b>	
11 Protocol	DS301
12 Galvanically isolated	no
<b>Hall sensors</b>	
13 Input voltage (24VDC tolerant)	VDC 0..5
14 Signal type	differential, open collector, single ended, 5VDC pull up intern 920 Ohm
<b>Digital input</b>	
15 Number	4 (Din0..3)
<b>Analog inputs</b>	
16 Number	1 (Ain0)
<b>Environment</b>	
17 Operating temperature	°C -40...+70

## Connection

X1 Motor		
1	FE	Functional earth
2	+Up	Power supply voltage
3	GND	Ground for power supply voltage
4	Ma	Motor phase A
5	Mb	Motor phase B
6	Mc	Motor phase C
X2 Hall and inc. encoder		
1	H1	Hall sensor 1
2	H2	Hall sensor 2
3	H3	Hall sensor 3
4	res.	Reserved
5	res.	Reserved
6	res.	Reserved
7	+U5V	5V output voltage for sensor supply Sensors: encoder, hall
8	/H1	Hall sensor 1 inverted
9	/H2	Hall sensor 2 inverted
10	/H3	Hall sensor 3 inverted
11	res.	Reserved
12	res.	Reserved
13	res.	Reserved
14	GND	Ground for sensor supply (don't connect with system GND)
X3 I/O's and CAN		
1	+Ue24V	Electronic supply voltage
2	Ain0	Analog input 0
3	Din0	Digital input 0
4	Din1	Digital input 1
5	Din2	Digital input 2
6	Din3	Digital input 3
7	GND	Ground for electronic supply voltage
8	res.	Reserved
9	res.	Reserved
10	CAN Hi	CAN High
11	CAN Lo	CAN Low
12	CAN GND	CAN Ground

# SVTE-A-E25-CanOpen Servo Drives

60VDC | 35A  
DC motors, BLDC motors

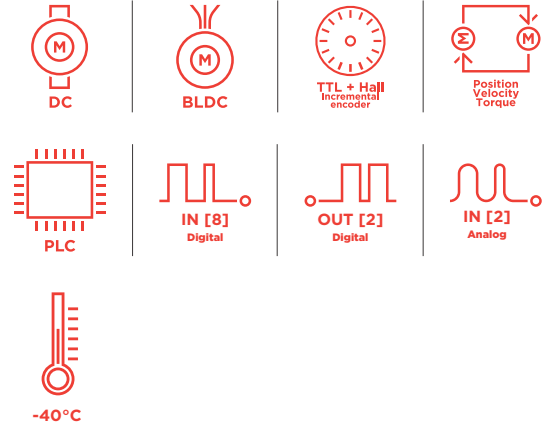
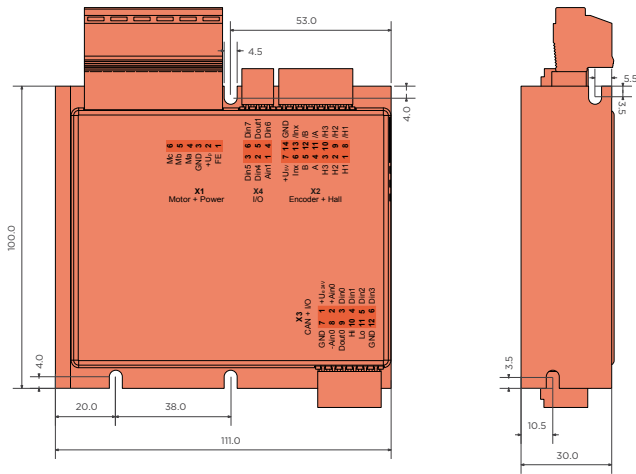

CANopen

Values	Unit
<b>Power</b>	
1 Electronic supply voltage $U_e$	VDC 9..30
2 Power supply voltage $U_p$	VDC 9..60
3 Max. output current	A 100
4 Continuous output current @ $U_p=24VDC$	A 35
5 Continuous output current @ $U_p=48VVDC$	A 26
6 Output voltage	Up to 100%
<b>Motor types</b>	
7 DC motors	yes
8 BLDC motors	yes
9 Stepper motors	no
<b>Mechanical</b>	
10 Size LxWxH	mm 111 x 100 x 30
<b>CAN bus</b>	
11 Protocol	DS301
12 Device profile	DS402
13 Galvanically isolated	yes
<b>Incremental encoder</b>	
14 Input voltage (24VDC tolerant)	VDC 0..5
15 Signal type	differential, open collector, single ended
<b>Hall sensors</b>	
16 Input voltage (24VDC tolerant)	VDC 0..5
17 Signal type	differential, open collector, single ended
<b>Digital input</b>	
18 Number	8 (Din0..7)
<b>Digital output</b>	
19 Number	2 (Dout0..1)
20 Continuous output current	A 1.5 (Load: resistive, inductive)
<b>Analog inputs</b>	
21 Number	2 (Ain0..1)
22 Signal type - Ain0	+/- 10 VDC, 12 Bit, differential
23 Signal type - Ain1	+/- 10 VDC, 12 Bit, single ended
<b>Environment</b>	
24 Operating temperature	°C -40...+70

## Connection

X1 Motor		
1	FE	Functional earth
2	+Up	Power supply voltage
3	GND	Ground for power supply voltage
4	Ma	Motor phase A
5	Mb	Motor phase B
6	Mc	Motor phase C
X2 Hall and inc. encoder		
1	H1	Hall sensor 1
2	H2	Hall sensor 2
3	H3	Hall sensor 3
4	A	Inc. encoder, A channel
5	B	Inc. encoder, B channel
6	Inx	Inc. encoder, index channel
7	+U5V	5V output voltage for sensor supply Sensors: encoder, hall
8	/H1	Hall sensor 1 inverted
9	/H2	Hall sensor 2 inverted
10	/H3	Hall sensor 3 inverted
11	/A	Inc. encoder, A channel invert
12	/B	Inc. encoder, B channel inverted
13	/Inx	Inc. encoder, index channel inverted
14	GND	Ground for sensor supply (don't connect with system GND)
X3 I/O's and CAN		
1	+Ue24V	Electronic supply voltage
2	+Ain0	Analog input 0, positive
3	Din0	Digital input 0
4	Din1	Digital input 1
5	Din2	Digital input 2
6	Din3	Digital input 3
7	GND	Ground for electronic supply voltage
8	-Ain0	Analog input 0, negative
9	Dout0	Digital output 0
10	CAN Hi	CAN High
11	CAN Lo	CAN Low
12	CAN GND	CAN Ground
X4 I/O's		
1	Ain1	Analog input 1
2	Din4	Digital input 4
3	Din5	Digital input 5
4	Din6	Digital input 6
5	Dout1	Digital output 1
6	Din7	Digital input 7

# SVTE-A-E25-EtherCAT Servo Drives

60VDC | 35A  
DC motors, BLDC motors

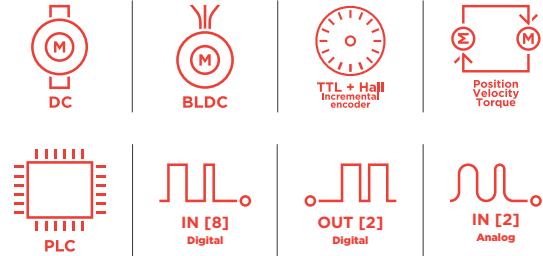
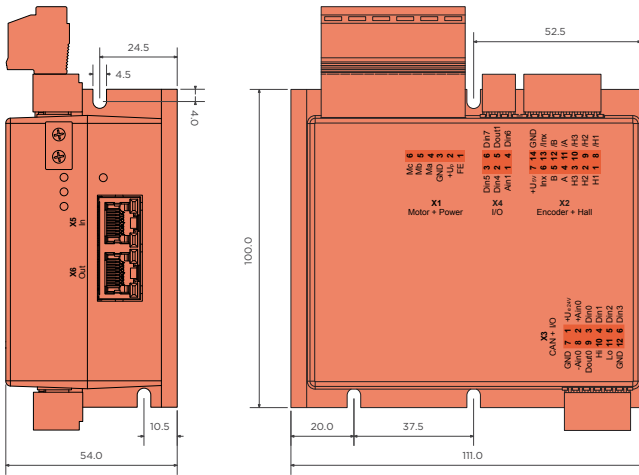

CANopen | EtherCAT

Values	Unit
<b>Power</b>	
1 Electronic supply voltage Ue	VDC 9..30
2 Power supply voltage Up	VDC 9..60
3 Max. output current	A 100
4 Continuous output current @ Up=24VDC	A 35
5 Continuous output current @ Up=48VDC	A 26
6 Output voltage	Up to 100%
<b>Motor types</b>	
7 DC motors	yes
8 BLDC motors	yes
9 Stepper motors	no
<b>Mechanical</b>	
10 Size LxWxH	mm 111 x 100 x 54
<b>CAN bus</b>	
11 Protocol	DS301
12 Device profile	DS402
13 Galvanically isolated	yes
<b>EtherCAT</b>	
14 Type	EtherCAT Slave
15 Physical layer	100 Base-Tx EtherCAT
16 Max. baudrate	100 Mbit/s
17 Number of ports	2xRJ45 (In,Out)
18 Protocol	CoE (CANopen over EtherCAT)
<b>Incremental encoder</b>	
19 Input voltage (24VDC tolerant)	VDC 0..5
20 Signal type	differential, open collector, single ended
<b>Hall sensors</b>	
21 Input voltage (24VDC tolerant)	VDC 0..5
22 Signal type	differential, open collector, single ended
<b>Digital input</b>	
23 Number	8 (Din0..7)
<b>Digital output</b>	
24 Number	2 (Dout0..1)
25 Continuous output current	A 1.5 (Load: resistive, inductive)
<b>Analog inputs</b>	
26 Number	2 (Ain0..1)
27 Signal type - Ain0	+/- 10 VDC, 12 Bit, differential
28 Signal type - Ain1	+/- 10 VDC, 12 Bit, single ended
<b>Environment</b>	
29 Operating temperature	°C -25...+70

## Connection

<b>X1 Motor</b>		
1	FE	Functional earth
2	+Up	Power supply voltage
3	GND	Ground for power supply voltage
4	Ma	Motor phase A
5	Mb	Motor phase B
6	Mc	Motor phase C
<b>X2 Hall and inc. encoder</b>		
1	H1	Hall sensor 1
2	H2	Hall sensor 2
3	H3	Hall sensor 3
4	A	Inc. encoder, A channel
5	B	Inc. encoder, B channel
6	Inx	Inc. encoder, index channel
7	+U5V	5V output voltage for sensor supply Sensors: encoder, hall
8	/H1	Hall sensor 1 inverted
9	/H2	Hall sensor 2 inverted
10	/H3	Hall sensor 3 inverted
11	/A	Inc. encoder, A channel invert
12	/B	Inc. encoder, B channel inverted
13	/Inx	Inc. encoder, index channel inverted
14	GND	Ground for sensor supply (don't connect with system GND)
<b>X3 I/O's and CAN</b>		
1	+Ue24V	Electronic supply voltage
2	+Ain0	Analog input 0, positive
3	Din0	Digital input 0
4	Din1	Digital input 1
5	Din2	Digital input 2
6	Din3	Digital input 3
7	GND	Ground for electronic supply voltage
8	-Ain0	Analog input 0, negative
9	Dout0	Digital output 0
10	CAN Hi	CAN High
11	CAN Lo	CAN Low
12	CAN GND	CAN Ground
<b>X4 I/O's</b>		
1	Ain1	Analog input 1
2	Din4	Digital input 4
3	Din5	Digital input 5
4	Din6	Digital input 6
5	Dout1	Digital output 1
6	Din7	Digital input 7
<b>X5 EtherCAT - In port</b>		
<b>X6 EtherCAT - Out port</b>		

# SVTE-A-E40-CanOpen Servo Drives

60VDC | 10A  
DC motors, BLDC motors

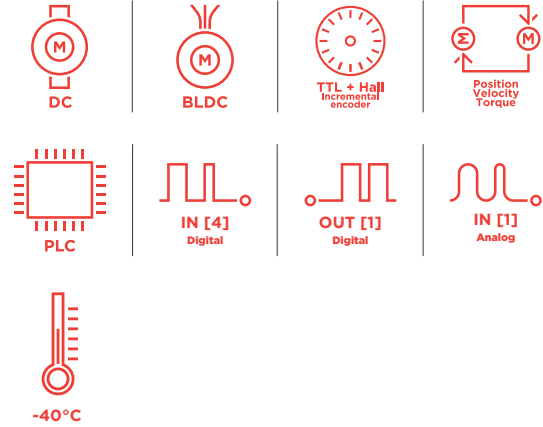
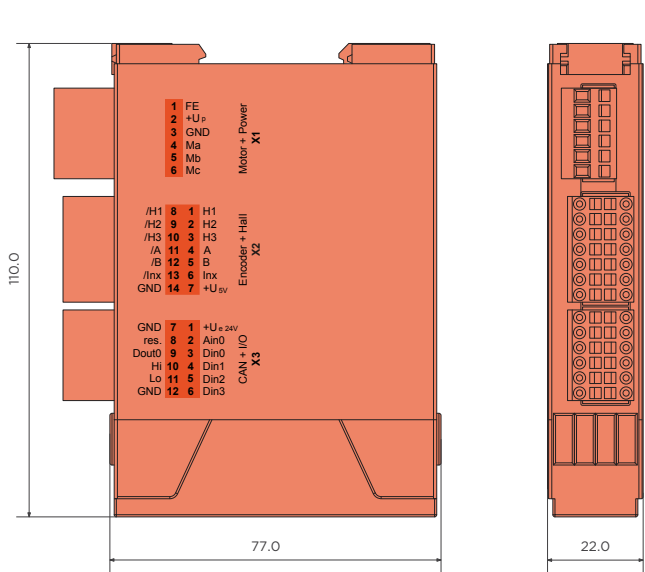

CANopen

Values	Unit
<b>Power</b>	
1 Electronic supply voltage U <sub>e</sub>	VDC 9..30
2 Power supply voltage U <sub>p</sub>	VDC 9..60
3 Max. output current	A 30
4 Continuous output current @ U <sub>p</sub> =24VDC	A 10
5 Continuous output current @ U <sub>p</sub> =48VDC	A 8.5
6 Output voltage	Up to 90%
<b>Motor types</b>	
7 DC motors	yes
8 BLDC motors	yes
9 Stepper motors	no
<b>Mechanical</b>	
10 Size LxWxH	mm 110 x 22.5 x 77
<b>CAN bus</b>	
11 Protocol	DS301
12 Device profile	DS402
13 Galvanically isolated	yes
<b>Incremental encoder</b>	
14 Input voltage (24VDC tolerant)	VDC 0..5
15 Signal type	differential, open collector, single ended
<b>Hall sensors</b>	
16 Input voltage (24VDC tolerant)	VDC 0..5
17 Signal type	differential, open collector, single ended
<b>Digital input</b>	
18 Number	4 (Din0..3)
<b>Digital output</b>	
19 Number	1 (Dout0..1)
20 Continuous output current	A 1.5 (Load: resistive, inductive)
<b>Analog inputs</b>	
21 Number	1 (Ain0..1)
22 Signal type	0..10 VDC, 12 Bit, single ended
<b>Environment</b>	
23 Operating temperature	°C -40...+70



## Connection

X1 Motor		
1	FE	Functional earth
2	+Up	Power supply voltage
3	GND	Ground for power supply voltage
4	Ma	Motor phase A
5	Mb	Motor phase B
6	Mc	Motor phase C
X2 Hall and inc. encoder		
1	H1	Hall sensor 1
2	H2	Hall sensor 2
3	H3	Hall sensor 3
4	A	Inc. encoder, A channel
5	B	Inc. encoder, B channel
6	Inx	Inc. encoder, index channel
7	+U5V	5V output voltage for sensor supply Sensors: encoder, hall
8	/H1	Hall sensor 1 inverted
9	/H2	Hall sensor 2 inverted
10	/H3	Hall sensor 3 inverted
11	/A	Inc. encoder, A channel invert
12	/B	Inc. encoder, B channel inverted
13	/Inx	Inc. encoder, index channel inverted
14	GND	Ground for sensor supply (don't connect with system GND)
X3 I/O's and CAN		
1	+Ue24V	Electronic supply voltage
2	Ain0	Analog input 0
3	Din0	Digital input 0
4	Din1	Digital input 1
5	Din2	Digital input 2
6	Din3	Digital input 3
7	GND	Ground for electronic supply voltage
8	res.	Reserved
9	Dout0	Digital output 0
10	CAN Hi	CAN High
11	CAN Lo	CAN Low
12	CAN GND	CAN Ground

# SVTE-A-E40-EtherCAT Servo Drives

60VDC | 10A  
DC motors, BLDC motors

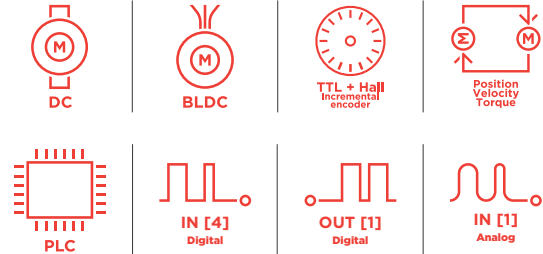
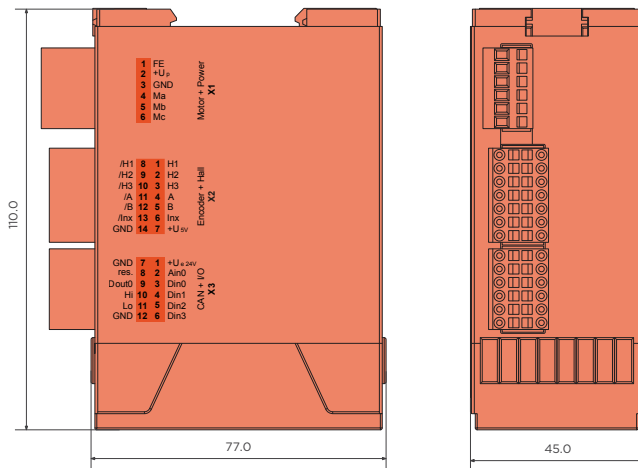

CANopen | EtherCAT

Values	Unit
<b>Power</b>	
1 Electronic supply voltage U <sub>e</sub>	VDC 9..30
2 Power supply voltage U <sub>p</sub>	VDC 9..60
3 Max. output current	A 30
4 Continuous output current @ U <sub>p</sub> =24VDC	A 10
5 Continuous output current @ U <sub>p</sub> =48VDC	A 8.5
6 Output voltage	Up to 90%
<b>Motor types</b>	
7 DC motors	yes
8 BLDC motors	yes
9 Stepper motors	no
<b>Mechanical</b>	
10 Size LxWxH	mm 110 x 45 x 77
<b>CAN bus</b>	
11 Protocol	DS301
12 Device profile	DS402
13 Galvanically isolated	no
<b>EtherCAT</b>	
14 Type	EtherCAT Slave
15 Physical layer	100 Base-Tx EtherCAT
16 Max. baudrate	100 Mbit/s
17 Number of ports	2xRJ45 (In,Out)
18 Protocol	CoE (CANopen over EtherCAT)
<b>Incremental encoder</b>	
19 Input voltage (24VDC tolerant)	VDC 0..5
20 Signal type	differential, open collector, single ended
<b>Hall sensors</b>	
21 Input voltage (24VDC tolerant)	VDC 0..5
22 Signal type	differential, open collector, single ended
<b>Digital input</b>	
23 Number	4 (Din0..3)
<b>Digital output</b>	
24 Number	1 (Dout0..1)
25 Continuous output current	A 1.5 (Load: resistive, inductive)
<b>Analog inputs</b>	
26 Number	1 (Ain0..1)
27 Signal type - Ain0	0..10 VDC, 12 Bit, single ended
<b>Environment</b>	
28 Operating temperature	°C -25...+70

## Connection

<b>X1 Motor</b>		
1	FE	Functional earth
2	+Up	Power supply voltage
3	GND	Ground for power supply voltage
4	Ma	Motor phase A
5	Mb	Motor phase B
6	Mc	Motor phase C
<b>X2 Hall and inc. encoder</b>		
1	H1	Hall sensor 1
2	H2	Hall sensor 2
3	H3	Hall sensor 3
4	A	Inc. encoder, A channel
5	B	Inc. encoder, B channel
6	Inx	Inc. encoder, index channel
7	+U5V	5V output voltage for sensor supply Sensors: encoder, hall
8	/H1	Hall sensor 1 inverted
9	/H2	Hall sensor 2 inverted
10	/H3	Hall sensor 3 inverted
11	/A	Inc. encoder, A channel invert
12	/B	Inc. encoder, B channel inverted
13	/Inx	Inc. encoder, index channel inverted
14	GND	Ground for sensor supply (don't connect with system GND)
<b>X3 I/O's and CAN</b>		
1	+Ue24V	Electronic supply voltage
2	Ain0	Analog input 0
3	Din0	Digital input 0
4	Din1	Digital input 1
5	Din2	Digital input 2
6	Din3	Digital input 3
7	GND	Ground for electronic supply voltage
8	res.	Reserved
9	Dout0	Digital output 0
10	CAN Hi	CAN High
11	CAN Lo	CAN Low
12	CAN GND	CAN Ground
<b>X5 EtherCAT - In port</b>		
<b>X6 EtherCAT - Out port</b>		

# SVTE-A-E45-CanOpen Servo Drives

60VDC | 10A  
DC motors, BLDC motors

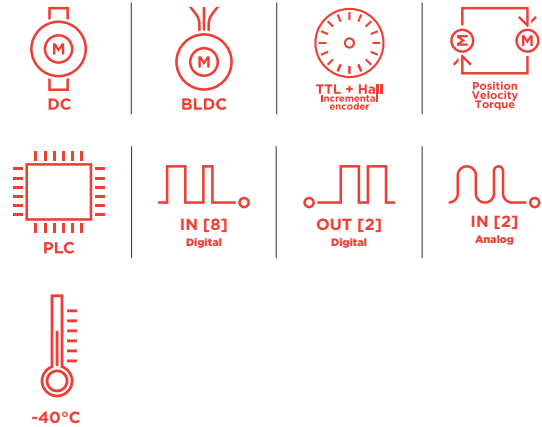
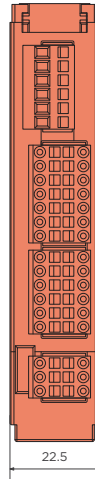
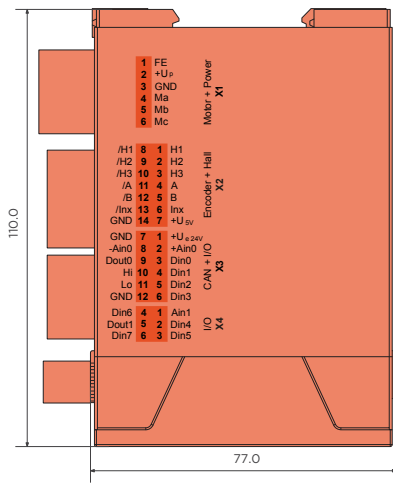

CANopen

Values	Unit
<b>Power</b>	
1 Electronic supply voltage U <sub>e</sub>	VDC 9..30
2 Power supply voltage U <sub>p</sub>	VDC 9..60
3 Max. output current	A 50
4 Continuous output current @ U <sub>p</sub> =24VDC	A 10
5 Continuous output current @ U <sub>p</sub> =48VDC	A 8.5
6 Output voltage	Up to 100%
<b>Motor types</b>	
7 DC motors	yes
8 BLDC motors	yes
9 Stepper motors	no
<b>Mechanical</b>	
10 Size LxWxH	mm 110 x 22.5 x 77
<b>CAN bus</b>	
11 Protocol	DS301
12 Device profile	DS402
13 Galvanically isolated	no
<b>Incremental encoder</b>	
14 Input voltage (24VDC tolerant)	V 0..5
15 Signal type	differential, open collector, single ended
<b>Hall sensors</b>	
16 Input voltage (24VDC tolerant)	V 0..5
17 Signal type	differential, open collector, single ended
<b>Digital input</b>	
18 Number	8 (Din0..7)
<b>Digital output</b>	
19 Number	2 (Dout0..1)
20 Continuous output current	A 1.5 (Load: resistive, inductive)
<b>Analog inputs</b>	
21 Number	2 (Ain0..1)
22 Signal type - Ain0	+/- 10 VDC, 12 Bit, differential
23 Signal type - Ain1	+/- 10 VDC, 12 Bit, single ended
<b>Environment</b>	
24 Operating temperature	°C -40...+70

## Connection

<b>X1 Motor</b>		
1	FE	Functional earth
2	+Up	Power supply voltage
3	GND	Ground for power supply voltage
4	Ma	Motor phase A
5	Mb	Motor phase B
6	Mc	Motor phase C
<b>X2 Hall and inc. encoder</b>		
1	H1	Hall sensor 1
2	H2	Hall sensor 2
3	H3	Hall sensor 3
4	A	Inc. encoder, A channel
5	B	Inc. encoder, B channel
6	Inx	Inc. encoder, index channel
7	+U5V	5V output voltage for sensor supply Sensors: encoder, hall
8	/H1	Hall sensor 1 inverted
9	/H2	Hall sensor 2 inverted
10	/H3	Hall sensor 3 inverted
11	/A	Inc. encoder, A channel invert
12	/B	Inc. encoder, B channel inverted
13	/Inx	Inc. encoder, index channel inverted
14	GND	Ground for sensor supply (don't connect with system GND)
<b>X3 I/O's and CAN</b>		
1	+Ue24V	Electronic supply voltage
2	+Ain0	Analog input 0, positive
3	Din0	Digital input 0
4	Din1	Digital input 1
5	Din2	Digital input 2
6	Din3	Digital input 3
7	GND	Ground for electronic supply voltage
8	-Ain0	Analog input 0, negative
9	Dout0	Digital output 0
10	CAN Hi	CAN High
11	CAN Lo	CAN Low
12	CAN GND	CAN Ground
<b>X4 I/O's</b>		
1	Ain1	Analog input 1
2	Din4	Digital input 4
3	Din5	Digital input 5
4	Din6	Digital input 6
5	Dout1	Digital output 1
6	Din7	Digital input 7

# SVTE-A-E45-EtherCAT Servo Drives

60VDC | 10A  
DC motors, BLDC motors

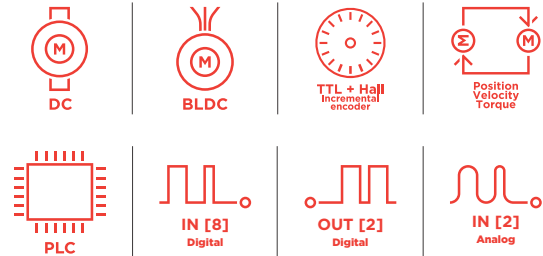
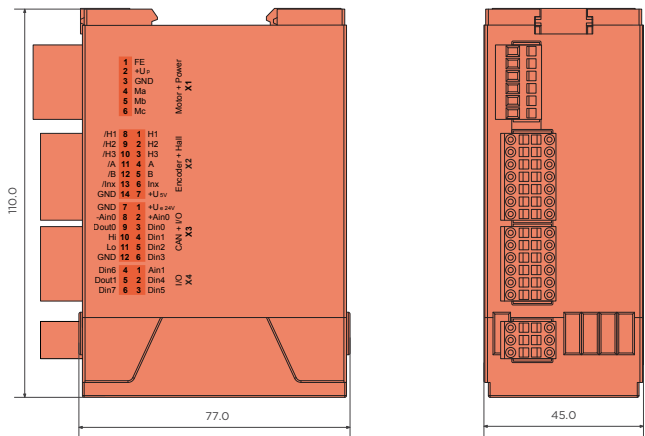

CANopen | EtherCAT

Values	Unit
<b>Power</b>	
1 Electronic supply voltage U <sub>e</sub>	VDC 9..30
2 Power supply voltage U <sub>p</sub>	VDC 9..60
3 Max. output current	A 50
4 Continuous output current @ U <sub>p</sub> =24VDC	A 10
5 Continuous output current @ U <sub>p</sub> =48VDC	A 8.5
6 Output voltage	Up to 100%
<b>Motor types</b>	
7 DC motors	yes
8 BLDC motors	yes
9 Stepper motors	no
<b>Mechanical</b>	
10 Size LxWxH	mm 110 x 45 x 77
<b>CAN bus</b>	
11 Protocol	DS301
12 Device profile	DS402
13 Galvanically isolated	no
<b>EtherCAT</b>	
14 Type	EtherCAT Slave
15 Physical layer	100 Base-Tx EtherCAT
16 Max. baudrate	100 Mbit/s
17 Number of ports	2xRJ45 (In,Out)
18 Protocol	CoE (CANopen over EtherCAT)
<b>Incremental encoder</b>	
19 Input voltage (24VDC tolerant)	VDC 0..5
20 Signal type	differential, open collector, single ended
<b>Hall sensors</b>	
21 Input voltage (24VDC tolerant)	VDC 0..5
22 Signal type	differential, open collector, single ended
<b>Digital input</b>	
23 Number	8 (Din0..7)
<b>Digital output</b>	
24 Number	2 (Dout0..1)
25 Continuous output current	A 1.5 (Load: resistive, inductive)
<b>Analog inputs</b>	
26 Number	2 (Ain0..1)
27 Signal type - Ain0	+/- 10 VDC, 12 Bit, differential
28 Signal type - Ain1	+/- 10 VDC, 12 Bit, single ended
<b>Environment</b>	
29 Operating temperature	°C -25...+70

## Connection

<b>X1 Motor</b>		
1	FE	Functional earth
2	+Up	Power supply voltage
3	GND	Ground for power supply voltage
4	Ma	Motor phase A
5	Mb	Motor phase B
6	Mc	Motor phase C
<b>X2 Hall and inc. encoder</b>		
1	H1	Hall sensor 1
2	H2	Hall sensor 2
3	H3	Hall sensor 3
4	A	Inc. encoder, A channel
5	B	Inc. encoder, B channel
6	Inx	Inc. encoder, index channel
7	+U5V	5V output voltage for sensor supply Sensors: encoder, hall
8	/H1	Hall sensor 1 inverted
9	/H2	Hall sensor 2 inverted
10	/H3	Hall sensor 3 inverted
11	/A	Inc. encoder, A channel invert
12	/B	Inc. encoder, B channel inverted
13	/Inx	Inc. encoder, index channel inverted
14	GND	Ground for sensor supply (don't connect with system GND)
<b>X3 I/O's and CAN</b>		
1	+Ue24V	Electronic supply voltage
2	+Ain0	Analog input 0, positive
3	Din0	Digital input 0
4	Din1	Digital input 1
5	Din2	Digital input 2
6	Din3	Digital input 3
7	GND	Ground for electronic supply voltage
8	-Ain0	Analog input 0, negative
9	Dout0	Digital output 0
10	CAN Hi	CAN High
11	CAN Lo	CAN Low
12	CAN GND	CAN Ground
<b>X4 I/O's</b>		
1	Ain1	Analog input 1
2	Din4	Digital input 4
3	Din5	Digital input 5
4	Din6	Digital input 6
5	Dout1	Digital output 1
6	Din7	Digital input 7
<b>X5 EtherCAT - In port</b>		
<b>X6 EtherCAT - Out port</b>		

# SVTE-A-E45-Profinet Servo Drives

60VDC | 10A  
DC motors, BLDC motors

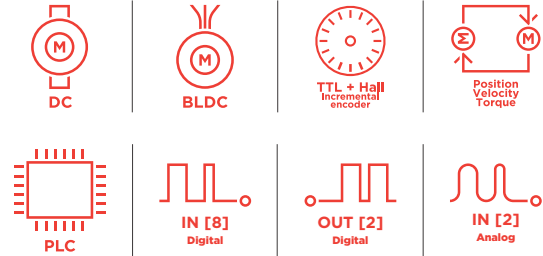
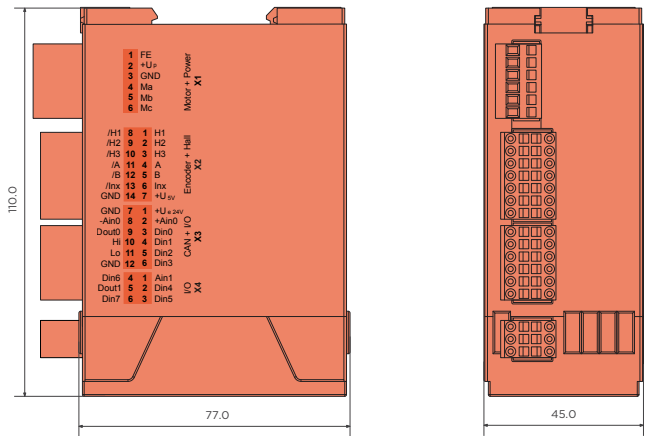

CANopen | PROFIBUS NET

Values	Unit
<b>Power</b>	
1 Electronic supply voltage Ue	VDC 9..30
2 Power supply voltage Up	VDC 9..60
3 Max. output current	A 50
4 Continuous output current @ Up=24VDC	A 10
5 Continuous output current @ Up=48VDC	A 8.5
6 Output voltage	Up to 100%
<b>Motor types</b>	
7 DC motors	yes
8 BLDC motors	yes
9 Stepper motors	no
<b>Mechanical</b>	
10 Size LxWxH	mm 110 x 45 x 77
<b>CAN bus</b>	
11 Protocol	DS301
12 Device profile	DS402
13 Galvanically isolated	no
<b>Profinet</b>	
14 Type	Slave
15 Physical layer	100 Base-Tx
16 Max. baudrate	100 Mbit/s
17 Number of ports	2xRJ45 (PORT1,PORT2)
<b>Incremental encoder</b>	
18 Input voltage (24VDC tolerant)	VDC 0..5
19 Signal type	differential, open collector, single ended
<b>Hall sensors</b>	
20 Input voltage (24VDC tolerant)	VDC 0..5
21 Signal type	differential, open collector, single ended
<b>Digital input</b>	
22 Number	8 (Din0..7)
<b>Digital output</b>	
23 Number	2 (Dout0..1)
24 Continuous output current	A 1.5 (Load: resistive, inductive)
<b>Analog inputs</b>	
25 Number	2 (Ain0..1)
26 Signal type - Ain0	+/- 10 Vdc, 12 Bit, differential
27 Signal type - Ain1	+/- 10 Vdc, 12 Bit, single ended
<b>Environment</b>	
28 Operating temperature	°C -25...+40



## Connection

<b>X1 Motor</b>		
1	FE	Functional earth
2	+Up	Power supply voltage
3	GND	Ground for power supply voltage
4	Ma	Motor phase A
5	Mb	Motor phase B
6	Mc	Motor phase C
<b>X2 Hall and inc. encoder</b>		
1	H1	Hall sensor 1
2	H2	Hall sensor 2
3	H3	Hall sensor 3
4	A	Inc. encoder, A channel
5	B	Inc. encoder, B channel
6	Inx	Inc. encoder, index channel
7	+U5V	5V output voltage for sensor supply Sensors: encoder, hall
8	/H1	Hall sensor 1 inverted
9	/H2	Hall sensor 2 inverted
10	/H3	Hall sensor 3 inverted
11	/A	Inc. encoder, A channel invert
12	/B	Inc. encoder, B channel inverted
13	/Inx	Inc. encoder, index channel inverted
14	GND	Ground for sensor supply (don't connect with system GND)
<b>X3 I/O's and CAN</b>		
1	+Ue24V	Electronic supply voltage
2	+Ain0	Analog input 0, positive
3	Din0	Digital input 0
4	Din1	Digital input 1
5	Din2	Digital input 2
6	Din3	Digital input 3
7	GND	Ground for electronic supply voltage
8	-Ain0	Analog input 0, negative
9	Dout0	Digital output 0
10	CAN Hi	CAN High
11	CAN Lo	CAN Low
12	CAN GND	CAN Ground
<b>X4 I/O's</b>		
1	Ain1	Analog input 1
2	Din4	Digital input 4
3	Din5	Digital input 5
4	Din6	Digital input 6
5	Dout1	Digital output 1
6	Din7	Digital input 7
<b>X5 Profinet - PORT1</b>		
<b>X6 Profinet - PORT2</b>		

# SVTE-A-E47-CanOpen Servo Drives

60VDC | 10A  
DC motors, BLDC motors

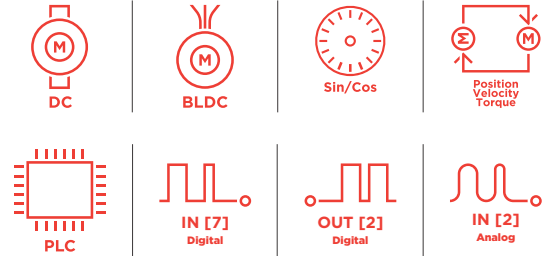
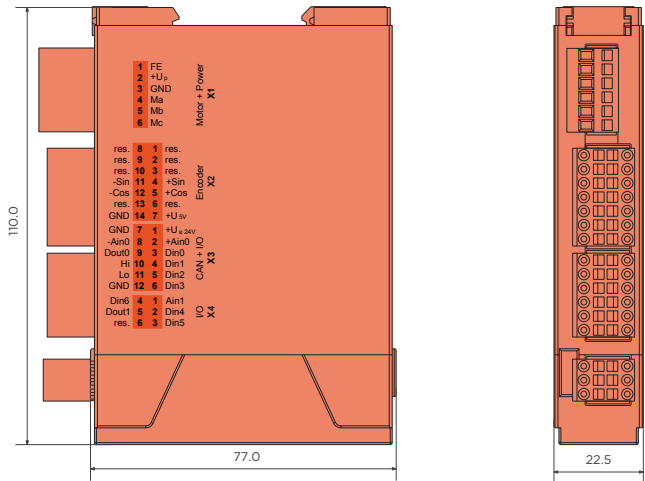

CANopen

Values	Unit
<b>Power</b>	
1 Electronic supply voltage $U_e$	VDC 9..30
2 Power supply voltage $U_p$	VDC 9..60
3 Max. output current	A 50
4 Continuous output current @ $U_p=24VDC$	A 10
5 Continuous output current @ $U_p=48VDC$	A 8.5
6 Output voltage	Up to 100%
<b>Motor types</b>	
7 DC motors	yes
8 BLDC motors	yes
9 Stepper motors	no
<b>Mechanical</b>	
10 Size LxWxH	mm 110 x 22.5 x 77
<b>CAN bus</b>	
11 Protocol	DS301
12 Device profile	DS402
13 Galvanically isolated	no
<b>Encoder</b>	
14 Input voltage	VDC 1 V peak-peak, differential
15 Signal type	sin / cos, analog, differential
16 Resolution	13 bit per sine period
<b>Digital input</b>	
17 Number	7 (Din0..6)
<b>Digital output</b>	
18 Number	2 (Dout0..1)
19 Continuous output current	A 1.5 (Load: resistive, inductive)
<b>Analog inputs</b>	
20 Number	2 (Ain0..1)
21 Signal type - Ain0	+/- 10 Vdc, 12 Bit, differential
22 Signal type - Ain1	+/- 10 Vdc, 12 Bit, single ended
<b>Environment</b>	
23 Operating temperature	°C -40...+70

## Connection

X1 Motor		
1	FE	Functional earth
2	+Up	Power supply voltage
3	GND	Ground for power supply voltage
4	Ma	Motor phase A
5	Mb	Motor phase B
6	Mc	Motor phase C
X2 Encoder sin/cos		
1	res.	Reserved
2	res.	Reserved
3	res.	Reserved
4	+Sin	Sine + signal
5	+Cos	Cosine + signal
6	res.	Reserved
7	+U5V	5V output voltage for sensor supply Sensors: encoder
8	res.	Reserved
9	res.	Reserved
10	res.	Reserved
11	-Sin	Sine - signal
12	-Cos	Cosine - signal
13	res.	Reserved
14	GND	Ground for sensor supply Notice: don't connect with system GND
X3 I/O's and CAN		
1	+Ue24V	Electronic supply voltage
2	+Ain0	Analog input 0, positive
3	Din0	Digital input 0
4	Din1	Digital input 1
5	Din2	Digital input 2
6	Din3	Digital input 3
7	GND	Ground for electronic supply voltage
8	-Ain0	Analog input 0, negative
9	Dout0	Digital output 0
10	CAN Hi	CAN High
11	CAN Lo	CAN Low
12	CAN GND	CAN Ground
X4 I/O's		
1	Ain1	Analog input 1
2	Din4	Digital input 4
3	Din5	Digital input 5
4	Din6	Digital input 6
5	Dout1	Digital output 1
6	res.	Reserved

# SVTE-A-E47-EtherCAT Servo Drives

60VDC | 10A  
DC motors, BLDC motors

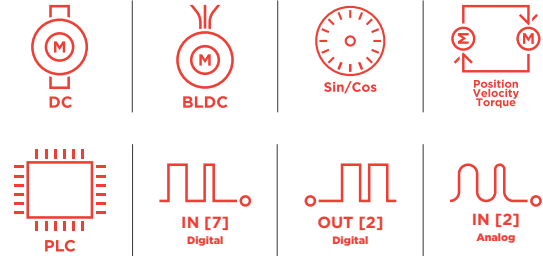
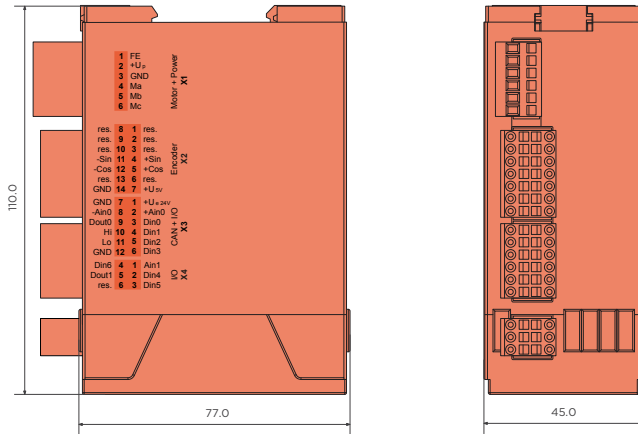

CANopen | EtherCAT

Values	Unit
<b>Power</b>	
1 Electronic supply voltage U <sub>e</sub>	VDC 9..30
2 Power supply voltage U <sub>p</sub>	VDC 9..60
3 Max. output current	A 50
4 Continuous output current @ U <sub>p</sub> =24VDC	A 10
5 Continuous output current @ U <sub>p</sub> =48VDC	A 8.5
6 Output voltage	Up to 100%
<b>Motor types</b>	
7 DC motors	yes
8 BLDC motors	yes
9 Stepper motors	no
<b>Mechanical</b>	
10 Size LxWxH	mm 110 x 45 x 77
<b>CAN bus</b>	
11 Protocol	DS301
12 Device profile	DS402
13 Galvanically isolated	no
<b>EtherCAT</b>	
14 Type	EtherCAT Slave
15 Physical layer	100 Base-Tx EtherCAT
16 Max. baudrate	100 Mbit/s
17 Number of ports	2xRJ45 (In,Out)
18 Protocol	CoE (CANopen over EtherCAT)
<b>Encoder</b>	
19 Input voltage	sin / cos
20 Signal type	1 Vdc peak-peak, differential
21 Resolution	13 bit per sine period
<b>Digital input</b>	
22 Number	7 (Din0..6)
<b>Digital output</b>	
23 Number	2 (Dout0..1)
24 Continuous output current	A 1.5 (Load: resistive, inductive)
<b>Analog inputs</b>	
25 Number	2 (Ain0..1)
26 Signal type - Ain0	+/- 10 Vdc, 12 Bit, differential
27 Signal type - Ain1	+/- 10 Vdc, 12 Bit, single ended
<b>Environment</b>	
28 Operating temperature	°C -25...+70

## Connection

<b>X1 Motor</b>		
1	FE	Functional earth
2	+Up	Power supply voltage
3	GND	Ground for power supply voltage
4	Ma	Motor phase A
5	Mb	Motor phase B
6	Mc	Motor phase C
<b>X2 Encoder sin/cos</b>		
1	res.	Reserved
2	res.	Reserved
3	res.	Reserved
4	+Sin	Sine + signal
5	+Cos	Cosine + signal
6	res.	Reserved
7	+U5V	5V output voltage for sensor supply Sensors: encoder
8	res.	Reserved
9	res.	Reserved
10	res.	Reserved
11	-Sin	Sine - signal
12	-Cos	Cosine - signal
13	res.	Reserved
14	GND	Ground for sensor supply (don't connect with system GND)
<b>X3 I/O's and CAN</b>		
1	+Ue24V	Electronic supply voltage
2	+Ain0	Analog input 0, positive
3	Din0	Digital input 0
4	Din1	Digital input 1
5	Din2	Digital input 2
6	Din3	Digital input 3
7	GND	Ground for electronic supply voltage
8	-Ain0	Analog input 0, negative
9	Dout0	Digital output 0
10	CAN Hi	CAN High
11	CAN Lo	CAN Low
12	CAN GND	CAN Ground
<b>X4 I/O's</b>		
1	Ain1	Analog input 1
2	Din4	Digital input 4
3	Din5	Digital input 5
4	Din6	Digital input 6
5	Dout1	Digital output 1
6	res.	Reserved
<b>X5 EtherCAT - PORT1</b>		
<b>X6 EtherCAT - PORT2</b>		

# SVTE-A-E50-CanOpen Servo Drives

60VDC | 7.5A  
DC motors, BLDC motors

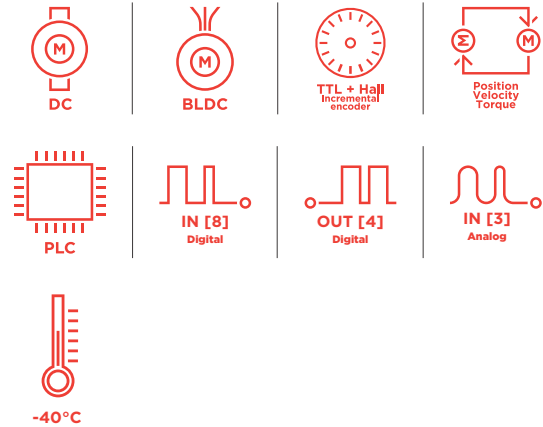
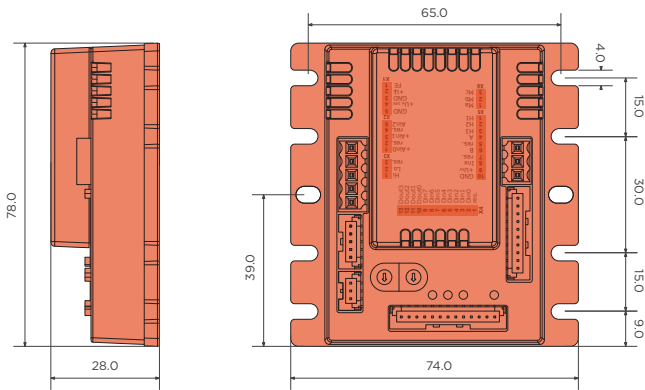

**CANopen**

Values	Unit
<b>Power</b>	
1 Electronic supply voltage Ue	VDC 9..30
2 Power supply voltage Up	VDC 9..60
3 Max. output current	A 25
4 Continuous output current @ Up=24VDC	A 7.5
5 Continuous output current @ Up=60VDC	A 7
6 Output voltage	Up to 90%
<b>Motor types</b>	
7 DC motors	Yes
8 BLDC motors	Yes
9 Stepper motors	No
<b>Mechanical</b>	
10 Size LxWxH	mm 78 x 74 x 28
<b>CAN bus</b>	
11 Protocol	DS301
12 Device profile	DS402
13 Galvanically isolated	no
<b>Incremental encoder</b>	
14 Input voltage	VDC 0..5
15 Signal type	open collector, single ended
<b>Hall sensors</b>	
16 Input voltage	VDC 0..5
17 Signal type	open collector, single ended
<b>Digital input</b>	
18 Number	8 (Din0..7)
<b>Digital output</b>	
19 Number	4 (Dout0..3)
20 Continuous output current	A 0.3 (Load: resistive, inductive)
<b>Analog inputs</b>	
21 Number	3 (Ain0..2)
22 Signal type - Ain0..1	0..10V, 12 Bit, Single Ended
23 Signal type - Ain2	0..5V, 12 Bit, Single Ended
<b>Environment</b>	
24 Operating temperature	°C -40..+70°C

## Connection

<b>X1 Supply</b>		
1	FE	Functional earth
2	+Up	Power supply voltage
3	GND	Ground for power supply voltage
4	+Ue24V	Electronic supply voltage
5	GND	Ground for electronic supply voltage
<b>X2 Analog Inputs</b>		
1	Ain0	Analog input 0
2	res.	Reserved
3	Ain1	Analog input 1
4	res.	Reserved
5	Ain2	Analog Input 2 (5V)
<b>X3 CAN bus</b>		
1	CAN Hi	CAN High
2	CAN Lo	CAN Low
3	res.	Reserved
<b>X4 Digital inputs/outputs</b>		
1	res.	Reserved
2	Din0	Digital input 0
3	Din1	Digital input 1
4	Din2	Digital input 2
5	Din3	Digital input 3
6	Din4	Digital input 4
7	Din5	Digital input 5
8	Din6	Digital input 6
9	Din7	Digital input 7
10	Dout0	Digital output 0
11	Dout1	Digital output 1
12	Dout2	Digital output 2
13	Dout3	Digital output 3
<b>X5 Hall and inc. encoder</b>		
1	H1	Hall sensor 1
2	H2	Hall sensor 2
3	H3	Hall sensor 3
4	A	Inc. encoder, A channel
5	res.	Reserved
6	B	Inc. encoder, B channel
7	res.	Reserved
8	Inx	Inc. encoder, index channel
9	+U5V	5V output voltage for sensor supply
10	GND	Ground for sensor supply (don't connect with system GND)
<b>X6 Motor</b>		
1	Ma	Motor phase A
2	Mb	Motor phase B
3	Mc	Motor phase C

# SVTE-A-E55-CanOpen Servo Drives

60VDC | 10A  
DC motors, BLDC motors

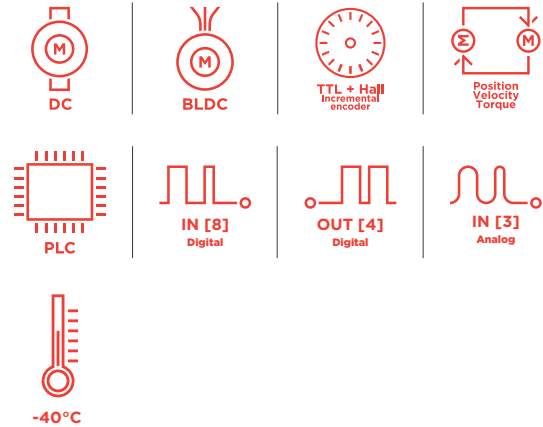
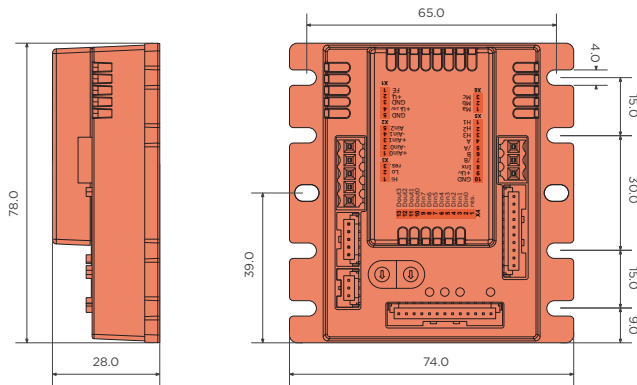

CANopen

Values	Unit
<b>Power</b>	
1 Electronic supply voltage $U_e$	VDC 9..30
2 Power supply voltage $U_p$	VDC 9..60
3 Max. output current	A 50
4 Continuous output current @ $U_p=24VDC$	A 10
5 Continuous output current @ $U_p=48VDC$	A 8.5
6 Output voltage	Up to 100%
<b>Motor types</b>	
7 DC motors	yes
8 BLDC motors	yes
9 Stepper motors	no
<b>Mechanical</b>	
10 Size LxWxH	mm 78 x 74 x 28
<b>CAN bus</b>	
11 Protocol	DS301
12 Device profile	DS402
13 Galvanically isolated	no
<b>Incremental encoder</b>	
14 Input voltage (24VDC tolerant)	VDC 0..5
15 Signal type	differential, open collector, single ended, 2,5 kOhm input impedance
<b>Hall sensor</b>	
16 Input voltage	VDC 0..5
17 Signal type	open collector, single ended, 5VDC pull up intern 920 Ohm
<b>Digital input</b>	
18 Number	8 (Din0..7)
<b>Digital output</b>	
19 Number	4 (Dout0..3)
20 Continuous output current	A 0.3 (Load: resistive, inductive)
<b>Analog inputs</b>	
21 Number	3 (Ain0..2)
22 Signal type - Ain0..1	+/- 10VDC, 12 Bit, differential, 200 kOhm input impedance
23 Signal type - Ain2	0..5 VDC, 12 Bit, single ended, 5VDC pull up intern 1,5 kOhm
<b>Environment</b>	
24 Operating temperature	°C -40...+70



## Connection

<b>X1 Supply</b>		
1	FE	Functional earth
2	+Up	Power supply voltage
3	GND	Ground for power supply voltage
4	+Ue24V	Electronic supply voltage
5	GND	Ground for electronic supply voltage
<b>X2 Analog Inputs</b>		
1	+Ain0	Analog input 0, positive
2	-Ain0	Analog input 0, negative
3	+Ain1	Analog input 1, positive
4	-Ain1	Analog input 1, negative
5	Ain2	Analog Input 2 (5V)
<b>X3 CAN bus</b>		
1	CAN Hi	CAN High
2	CAN Lo	CAN Low
3	res.	Reserved
<b>X4 Digital inputs/outputs</b>		
1	res.	Reserved
2	Din0	Digital input 0
3	Din1	Digital input 1
4	Din2	Digital input 2
5	Din3	Digital input 3
6	Din4	Digital input 4
7	Din5	Digital input 5
8	Din6	Digital input 6
9	Din7	Digital input 7
10	Dout0	Digital output 0
11	Dout1	Digital output 1
12	Dout2	Digital output 2
13	Dout3	Digital output 3
<b>X5 Hall and inc. encoder</b>		
1	H1	Hall sensor 1
2	H2	Hall sensor 2
3	H3	Hall sensor 3
4	A	Inc. encoder, A channel
5	/A	Inc. encoder, A channel invert
6	B	Inc. encoder, B channel
7	/B	Inc. encoder, B channel inverted
8	Inx	Inc. encoder, index channel
9	+U5V	5V output voltage for sensor supply
10	GND	Ground for sensor supply (don't connect with system GND)
<b>X6 Motor</b>		
1	Ma	Motor phase A
2	Mb	Motor phase B
3	Mc	Motor phase C

# SVTE-A-E55-EtherCAT Servo Drives

60VDC | 8A  
DC motors, BLDC motors

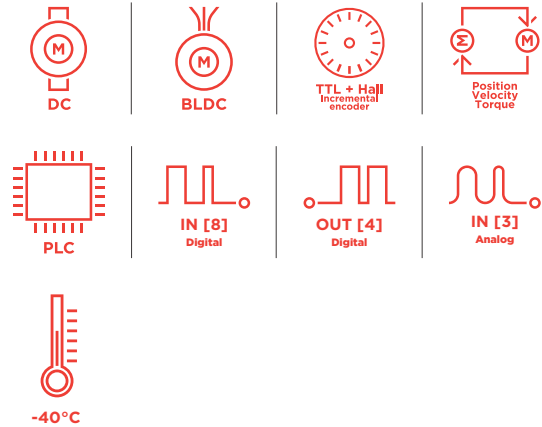
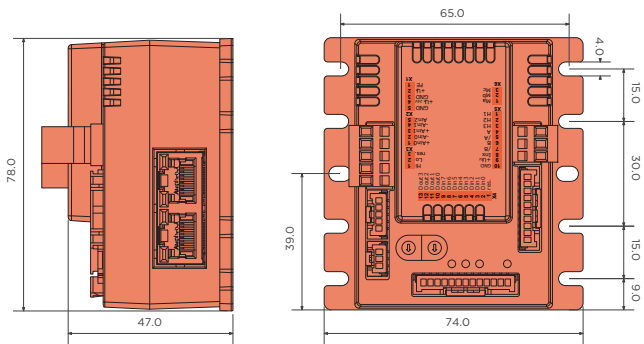

CANopen | EtherCAT

Values	Unit
<b>Power</b>	
1 Electronic supply voltage U <sub>e</sub>	VDC 9..30
2 Power supply voltage U <sub>p</sub>	VDC 9..60
3 Max. output current	A 50
4 Continuous output current	A 8
5 Output voltage	Up to 100%
<b>Motor types</b>	
6 DC motors	yes
7 BLDC motors	yes
8 Stepper motors	no
<b>Mechanical</b>	
9 Size LxWxH	mm 78x74x47
<b>CAN bus</b>	
10 Protocol	DS301
11 Device profile	DS402
12 Galvanically isolated	no
<b>EtherCAT</b>	
13 Type	EtherCAT Slave
14 Physical layer	100 Base-Tx EtherCAT
15 Max. baudrate	100 Mbit/s
16 Number of ports	2xRJ45 (In,Out)
17 Protocol	CoE (CANopen over EtherCAT)
<b>Incremental encoder</b>	
18 Input voltage (24VDC tolerant)	0..5
19 Signal type	differential, open collector, single ended
<b>Hall sensors</b>	
20 Input voltage	0..5
21 Signal type	open collector, single ended
<b>Digital input</b>	
22 Number	8 (Din0..7)
<b>Digital output</b>	
23 Number	4 (Dout0..3)
24 Continuous output current	A 0.3 (Load: resistive, inductive)
<b>Analog inputs</b>	
25 Number	3 (Ain0..2)
26 Signal type - Ain0..1	+/- 10 VDC, 12 Bit, differential
27 Signal type - Ain2	0..5VDC, 12 Bit, single ended
<b>Environment</b>	
28 Operating temperature	°C -40...+70

## Connection

<b>X1 Supply</b>		
1	FE	Functional earth
2	+Up	Power supply voltage
3	GND	Ground for power supply voltage
4	+Ue24V	Electronic supply voltage
5	GND	Ground for electronic supply voltage
<b>X2 Analog Inputs</b>		
1	+Ain0	Analog input 0, positive
2	-Ain0	Analog input 0, negative
3	+Ain1	Analog input 1, positive
4	-Ain1	Analog input 1, negative
5	Ain2	Analog Input 2 (5V)
<b>X3 CAN bus</b>		
1	CAN Hi	CAN High
2	CAN Lo	CAN Low
3	res.	Reserved
<b>X4 Digital inputs/outputs</b>		
1	res.	Reserved
2	Din0	Digital input 0
3	Din1	Digital input 1
4	Din2	Digital input 2
5	Din3	Digital input 3
6	Din4	Digital input 4
7	Din5	Digital input 5
8	Din6	Digital input 6
9	Din7	Digital input 7
10	Dout0	Digital output 0
11	Dout1	Digital output 1
12	Dout2	Digital output 2
13	Dout3	Digital output 3
<b>X5 Hall and inc. encoder</b>		
1	H1	Hall sensor 1
2	H2	Hall sensor 2
3	H3	Hall sensor 3
4	A	Inc. encoder, A channel
5	/A	Inc. encoder, A channel invert
6	B	Inc. encoder, B channel
7	/B	Inc. encoder, B channel inverted
8	Inx	Inc. encoder, index channel
9	+U5V	5V output voltage for sensor supply
10	GND	Ground for sensor supply (don't connect with system GND)
<b>X6 Motor</b>		
1	Ma	Motor phase A
2	Mb	Motor phase B
3	Mc	Motor phase C
<b>X7 EtherCAT - In port</b>		
<b>X8 EtherCAT - Out port</b>		

# SVTE-A-E55-Profinet Servo Drives

60VDC | 9A  
DC motors, BLDC motors

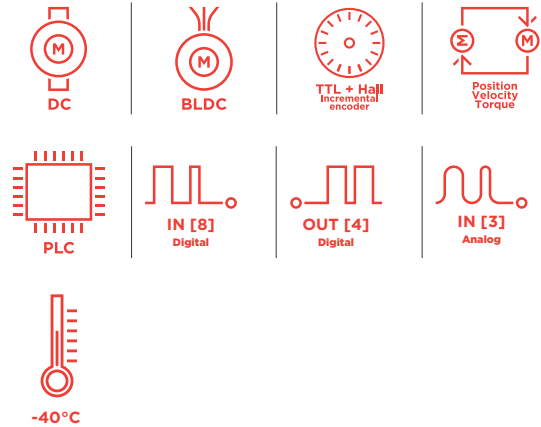
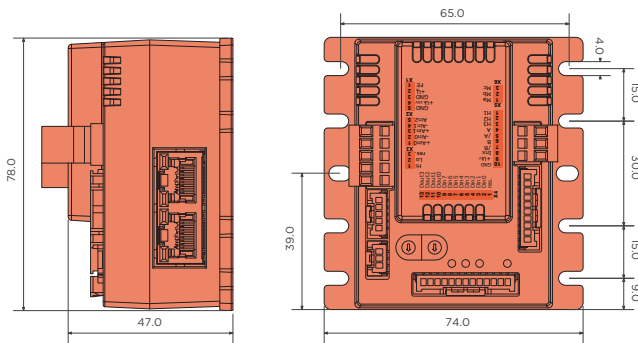

CANopen | PROFINET

Values	Unit
<b>Power</b>	
1 Electronic supply voltage Ue	VDC 9..30
2 Power supply voltage Up	VDC 9..60
3 Max. output current	A 50
4 Continuous output current @ Up=24VDC	A 9
5 Continuous output current @ Up=48VDC	A 8
6 Output voltage	Up to 100%
<b>Motor types</b>	
7 DC motors	yes
8 BLDC motors	yes
9 Stepper motors	no
<b>Mechanical</b>	
10 Size LxWxH	mm 78 x 74 x 47
<b>CAN bus</b>	
11 Protocol	DS301
12 Device profile	DS402
13 Galvanically isolated	no
<b>Profinet</b>	
14 Type	Slave
15 Physical layer	100 Base-Tx
16 Max. baudrate	100 Mbit/s
17 Number of ports	2xRJ45 (PORT1, PORT2)
<b>Incremental encoder</b>	
18 Input voltage (24VDC tolerant)	VDC 0..5
19 Signal type	differential, open collector, single ended, 2.5 kOhm input impedance
<b>Hall sensors</b>	
20 Input voltage	VDC 0..5
21 Signal type	open collector, single ended, 5VDC pull up intern 920 Ohm
<b>Digital input</b>	
22 Number	8 (Din0..7)
<b>Digital output</b>	
23 Number	4 (Dout0..3)
24 Continuous output current	A 0.3 (Load: resistive, inductive)
<b>Analog inputs</b>	
25 Number	3 (Ain0..2)
26 Signal type - Ain0...1	+/- 10 VDC, 12 Bit, differential, 20 kOhm input impedance
27 Signal type - Ain2	0..5 VDC, 12 Bit, single ended, 5VDC pull up intern 1.5 kOhm
<b>Environment</b>	
28 Operating temperature	°C -40...+70

## Connection

<b>X1 Supply</b>		
1	FE	Functional earth
2	+Up	Power supply voltage
3	GND	Ground for power supply voltage
4	+Ue24V	Electronic supply voltage
5	GND	Ground for electronic supply voltage
<b>X2 Analog Inputs</b>		
1	+Ain0	Analog input 0, positive
2	-Ain0	Analog input 0, negative
3	+Ain1	Analog input 1, positive
4	-Ain1	Analog input 1, negative
5	Ain2	Analog Input 2 (5V)
<b>X3 CAN bus</b>		
1	CAN Hi	CAN High
2	CAN Lo	CAN Low
3	res.	Reserved
<b>X4 Digital inputs/outputs</b>		
1	res.	Reserved
2	Din0	Digital input 0
3	Din1	Digital input 1
4	Din2	Digital input 2
5	Din3	Digital input 3
6	Din4	Digital input 4
7	Din5	Digital input 5
8	Din6	Digital input 6
9	Din7	Digital input 7
10	Dout0	Digital output 0
11	Dout1	Digital output 1
12	Dout2	Digital output 2
13	Dout3	Digital output 3
<b>X5 Hall and inc. encoder</b>		
1	H1	Hall sensor 1
2	H2	Hall sensor 2
3	H3	Hall sensor 3
4	A	Inc. encoder, A channel
5	/A	Inc. encoder, A channel invert
6	B	Inc. encoder, B channel
7	/B	Inc. encoder, B channel inverted
8	Inx	Inc. encoder, index channel
9	+U5V	5V output voltage for sensor supply
10	GND	Ground for sensor supply (don't connect with system GND)
<b>X6 Motor</b>		
1	Ma	Motor phase A
2	Mb	Motor phase B
3	Mc	Motor phase C
<b>X7 Profinet - In port</b>		
<b>X8 Profinet - Out port</b>		

# SVTE-A-E57-CanOpen Servo Drives

60VDC | 10A  
DC motors, BLDC motors

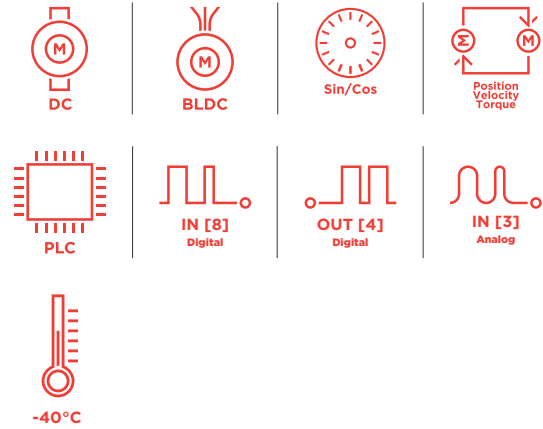
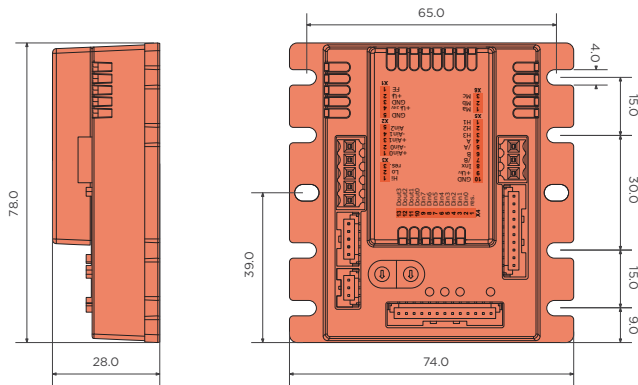

**CANopen**

Values	Unit
<b>Power</b>	
1 Electronic supply voltage Ue	VDC 9..30
2 Power supply voltage Up	VDC 9..60
3 Max. output current	A 50
4 Continuous output current @ Up=24VDC	A 10
5 Output voltage	Up to 100%
<b>Motor types</b>	
6 DC motors	yes
7 BLDC motors	yes
8 Stepper motors	no
<b>Mechanical</b>	
9 Size LxWxH	mm 78 x 74 x 28
<b>CAN bus</b>	
10 Protocol	DS301
11 Device profile	DS402
12 Galvanically isolated	no
<b>Encoder</b>	
13 Input voltage	VDC 1 VDC peak-peak, differential
14 Signal type	sin / cos, analog, differential, 1085 kOhm input impedance
15 Resolution	13 bit per sine period
<b>Digital input</b>	
16 Number	8 (Din0..7)
<b>Digital output</b>	
17 Number	4 (Dout0..3)
18 Continuous output current	A 0.3 (Load: resistive, inductive)
<b>Analog inputs</b>	
19 Number	3 (Ain0..2)
20 Signal type - Ain0..1	+/- 10VDC, 12 Bit, differential, 200 kOhm input impedance
21 Signal type - Ain2	0..5 VDC, 12 Bit, single ended, 5VDC pull up intern 1.5 kOhm
<b>Environment</b>	
21 Operating temperature	°C -40...+70

## Connection

<b>X1 Supply</b>		
1	FE	Functional earth
2	+Up	Power supply voltage
3	GND	Ground for power supply voltage
4	+Ue24V	Electronic supply voltage
5	GND	Ground for electronic supply voltage
<b>X2 Analog Inputs</b>		
1	+Ain0	Analog input 0, positive
2	-Ain0	Analog input 0, negative
3	+Ain1	Analog input 1, positive
4	-Ain1	Analog input 1, negative
5	Ain2	Analog Input 2 (5V)
<b>X3 CAN bus</b>		
1	CAN Hi	CAN High
2	CAN Lo	CAN Low
3	res.	Reserved
<b>X4 Digital inputs/outputs</b>		
1	res.	Reserved
2	Din0	Digital input 0
3	Din1	Digital input 1
4	Din2	Digital input 2
5	Din3	Digital input 3
6	Din4	Digital input 4
7	Din5	Digital input 5
8	Din6	Digital input 6
9	Din7	Digital input 7
10	Dout0	Digital output 0
11	Dout1	Digital output 1
12	Dout2	Digital output 2
13	Dout3	Digital output 3
<b>X5 Encoder SinCos</b>		
1	res.	Reserved
2	res.	Reserved
3	res.	Reserved
4	+Sin	Encoder, plus sine signal
5	-Sin	Encoder, minus sine signal
6	+Cos	Encoder, plus cosine signal
7	-Cos	Encoder, minus cosine signal
8	res.	Reserved
9	+U5V	5V output voltage for sensor supply
10	GND	Ground for sensor supply (don't connect with system GND)
<b>X6 Motor</b>		
1	Ma	Motor phase A
2	Mb	Motor phase B
3	Mc	Motor phase C

# SVTE-A-E50-HC-CanOpen Servo Drives

60VDC | 14.5A  
DC motors, BLDC motors

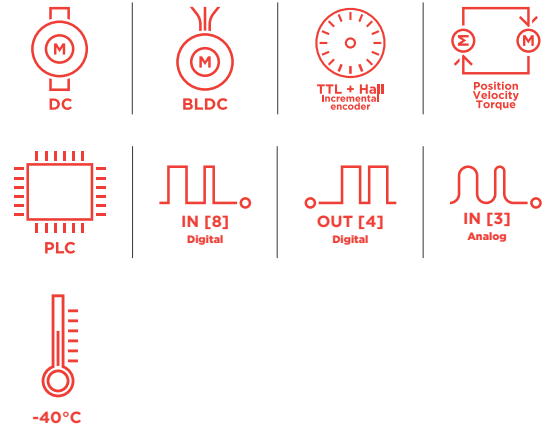
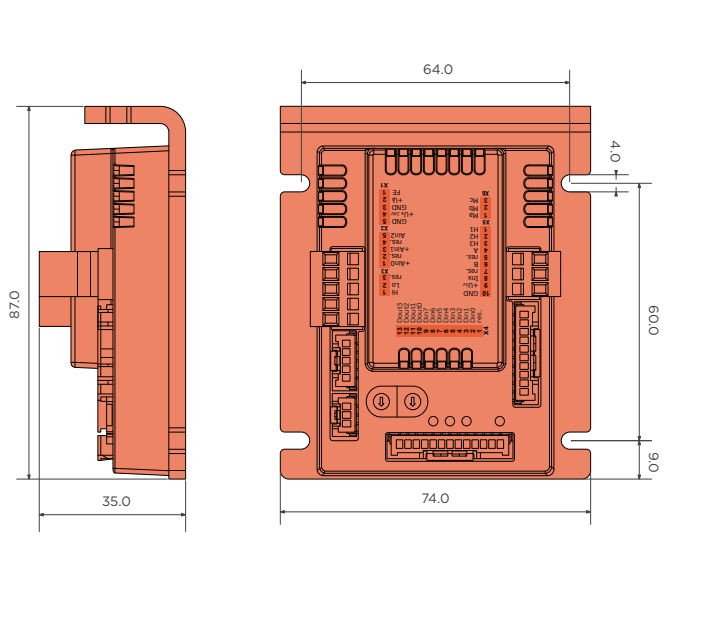

**CANopen**

Values	Unit
<b>Power</b>	
1 Electronic supply voltage U <sub>e</sub>	VDC 9..30
2 Power supply voltage U <sub>p</sub>	VDC 9..60
3 Max. output current	A 25
4 Continuous output current	A 14.5
5 Continuous output current @ U <sub>p</sub> =24VDC	A 9.5
6 Continuous output current @ U <sub>p</sub> =60VDC	A 9
7 Output voltage	Up to 90%
<b>Motor types</b>	
8 DC motors	Yes
9 BLDC motors	Yes
10 Stepper motors	No
<b>Mechanical</b>	
11 Size LxWxH	mm 87 x 74 x 28
<b>CAN bus</b>	
12 Protocol	DS301
13 Device profile	DS402
14 Galvanically isolated	no
<b>Incremental encoder</b>	
15 Input voltage	VDC 0..5
16 Signal type	open collector, single ended
<b>Hall sensors</b>	
17 Input voltage	VDC 0..5
18 Signal type	open collector, single ended
<b>Digital input</b>	
19 Number	8 (Din0..7)
<b>Digital output</b>	
20 Number	4 (Dout0..3)
21 Continuous output current	A 0.3 (Load: resistive, inductive)
<b>Analog inputs</b>	
22 Number	3 (Ain0..2)
23 Signal type - Ain0..1	0..10V, 12 Bit, Single Ended
24 Signal type - Ain2	0..5V, 12 Bit, Single Ended
<b>Environment</b>	
25 Operating temperature	°C -40..+70°C



## Connection

<b>X1 Supply</b>		
1	FE	Functional earth
2	+Up	Power supply voltage
3	GND	Ground for power supply voltage
4	+Ue24V	Electronic supply voltage
5	GND	Ground for electronic supply voltage
<b>X2 Analog Inputs</b>		
1	Ain0	Analog input 0
2	res.	Reserved
3	Ain1	Analog input 1
4	res.	Reserved
5	Ain2	Analog Input 2 (5V)
<b>X3 CAN bus</b>		
1	CAN Hi	CAN High
2	CAN Lo	CAN Low
3	res.	Reserved
<b>X4 Digital inputs/outputs</b>		
1	res.	Reserved
2	Din0	Digital input 0
3	Din1	Digital input 1
4	Din2	Digital input 2
5	Din3	Digital input 3
6	Din4	Digital input 4
7	Din5	Digital input 5
8	Din6	Digital input 6
9	Din7	Digital input 7
10	Dout0	Digital output 0
11	Dout1	Digital output 1
12	Dout2	Digital output 2
13	Dout3	Digital output 3
<b>X5 Hall and inc. encoder</b>		
1	H1	Hall sensor 1
2	H2	Hall sensor 2
3	H3	Hall sensor 3
4	A	Inc. encoder, A channel
5	res.	Reserved
6	B	Inc. encoder, B channel
7	res.	Reserved
8	Inx	Inc. encoder, index channel
9	+U5V	5V output voltage for sensor supply
10	GND	Ground for sensor supply (don't connect with system GND)
<b>X6 Motor</b>		
1	Ma	Motor phase A
2	Mb	Motor phase B
3	Mc	Motor phase C

# SVTE-A-E55-HC-CanOpen Servo Drives

60VDC | 14.5A  
DC motors, BLDC motors

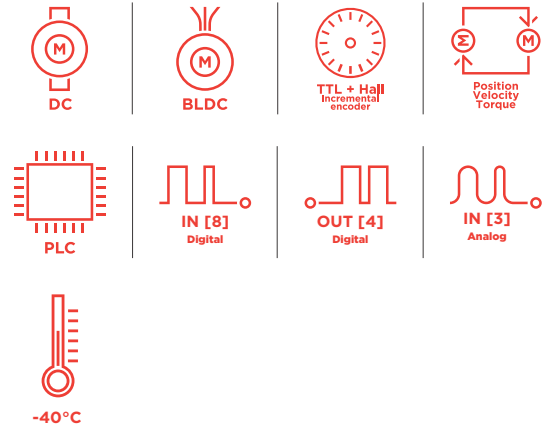
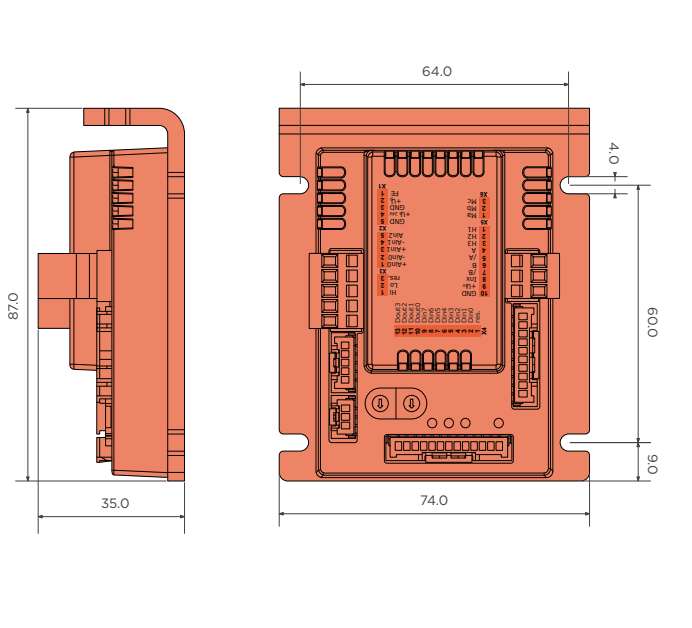

**CANopen**

Values	Unit
<b>Power</b>	
1 Electronic supply voltage Ue	VDC 9..30
2 Power supply voltage Up	VDC 9..60
3 Max. output current	A 50
4 Continuous output current	A 14.5
5 Continuous output current @ Up=24VDC	A 9.5
6 Continuous output current @ Up=60VDC	A 9
7 Output voltage	Up to 100%
<b>Motor types</b>	
8 DC motors	yes
9 BLDC motors	yes
10 Stepper motors	no
<b>Mechanical</b>	
11 Size LxWxH	mm 87 x 74 x 28
<b>CAN bus</b>	
12 Protocol	DS301
13 Device profile	DS402
14 Galvanically isolated	no
<b>Incremental encoder</b>	
15 Input voltage	VDC 0..5
16 Signal type	open collector, single ended
<b>Hall sensors</b>	
17 Input voltage	VDC 0..5
18 Signal type	open collector, single ended
<b>Digital input</b>	
19 Number	8 (Din0..7)
<b>Digital output</b>	
20 Number	4 (Dout0..3)
21 Continuous output current	A 0.3 (Load: resistive, inductive)
<b>Analog inputs</b>	
22 Number	3 (Ain0..2)
23 Signal type - Ain0..1	0..10V, 12 Bit, Single Ended
24 Signal type - Ain2	0..5V, 12 Bit, Single Ended
<b>Environment</b>	
24 Operating temperature	°C -40..+70°C

## Connection

<b>X1 Supply</b>		
1	FE	Functional earth
2	+Up	Power supply voltage
3	GND	Ground for power supply voltage
4	+Ue24V	Electronic supply voltage
5	GND	Ground for electronic supply voltage
<b>X2 Analog Inputs</b>		
1	+Ain0	Analog input 0, positive
2	-Ain0	Analog input 0, negative
3	+Ain1	Analog input 1, positive
4	-Ain1	Analog input 1, negative
5	Ain2	Analog Input 2 (5V)
<b>X3 CAN bus</b>		
1	CAN Hi	CAN High
2	CAN Lo	CAN Low
3	res.	Reserved
<b>X4 Digital inputs/outputs</b>		
1	res.	Reserved
2	Din0	Digital input 0
3	Din1	Digital input 1
4	Din2	Digital input 2
5	Din3	Digital input 3
6	Din4	Digital input 4
7	Din5	Digital input 5
8	Din6	Digital input 6
9	Din7	Digital input 7
10	Dout0	Digital output 0
11	Dout1	Digital output 1
12	Dout2	Digital output 2
13	Dout3	Digital output 3
<b>X5 Hall and inc. encoder</b>		
1	H1	Hall sensor 1
2	H2	Hall sensor 2
3	H3	Hall sensor 3
4	A	Inc. encoder, A channel
5	/A	Inc. encoder, A channel invert
6	B	Inc. encoder, B channel
7	/B	Inc. encoder, B channel inverted
8	Inx	Inc. encoder, index channel
9	+U5V	5V output voltage for sensor supply
10	GND	Ground for sensor supply (don't connect with system GND)
<b>X6 Motor</b>		
1	Ma	Motor phase A
2	Mb	Motor phase B
3	Mc	Motor phase C

# SVTE-A-E55-HC-EtherCAT Servo Drives

60VDC | 14.5A  
DC motors, BLDC motors

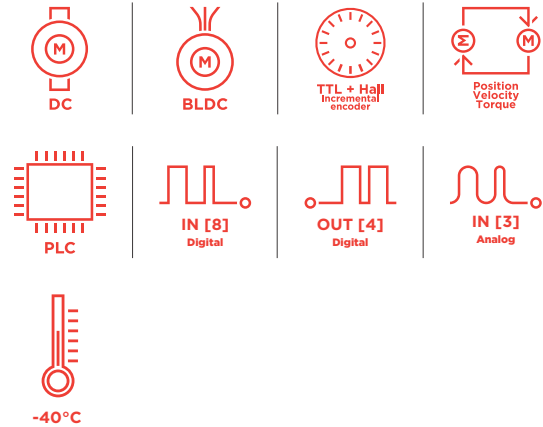
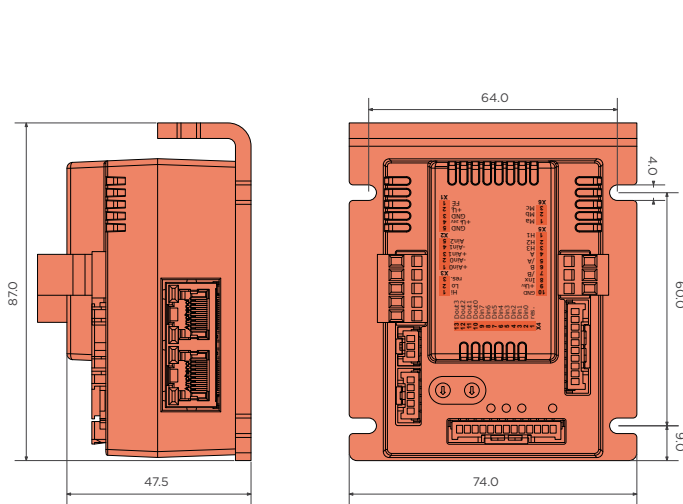

CANopen | EtherCAT

Values	Unit
<b>Power</b>	
1 Electronic supply voltage U <sub>e</sub>	VDC 9..30
2 Power supply voltage U <sub>p</sub>	VDC 9..60
3 Max. output current	A 50
4 Continuous output current	A 14.5
5 Output voltage	Up to 100%
<b>Motor types</b>	
6 DC motors	yes
7 BLDC motors	yes
8 Stepper motors	no
<b>Mechanical</b>	
9 Size LxWxH	mm 87 x 74 x 47
<b>CAN bus</b>	
10 Protocol	DS301
11 Device profile	DS402
12 Galvanically isolated	no
<b>EtherCAT</b>	
13 Type	EtherCAT Slave
14 Physical layer	100 Base-Tx EtherCAT
15 Max. baudrate	100 Mbit/s
16 Number of ports	2xRJ45 (In,Out)
17 Protocol	CoE (CANopen over EtherCAT)
<b>Incremental encoder</b>	
18 Input voltage	VDC 0..5
19 Signal type	differential, open collector, single ended
<b>Hall sensors</b>	
20 Input voltage	VDC 0..5
21 Signal type	open collector, single ended
<b>Digital input</b>	
22 Number	8 (Din0..7)
<b>Digital output</b>	
23 Number	4 (Dout0..3)
24 Continuous output current	A 0.3 (Load: resistive, inductive)
<b>Analog inputs</b>	
25 Number	3 (Ain0..2)
26 Signal type - Ain0..1	+/-10V, 12 Bit, differential
27 Signal type - Ain2	0..5V, 12 Bit, single ended
<b>Environment</b>	
28 Operating temperature	°C -40..+70°C

## Connection

<b>X1 Supply</b>		
1	FE	Functional earth
2	+Up	Power supply voltage
3	GND	Ground for power supply voltage
4	+Ue24V	Electronic supply voltage
5	GND	Ground for electronic supply voltage
<b>X2 Analog Inputs</b>		
1	+Ain0	Analog input 0, positive
2	-Ain0	Analog input 0, negative
3	+Ain1	Analog input 1, positive
4	-Ain1	Analog input 1, negative
5	Ain2	Analog Input 2 (5V)
<b>X3 CAN bus</b>		
1	CAN Hi	CAN High
2	CAN Lo	CAN Low
3	res.	Reserved
<b>X4 Digital inputs/outputs</b>		
1	res.	Reserved
2	Din0	Digital input 0
3	Din1	Digital input 1
4	Din2	Digital input 2
5	Din3	Digital input 3
6	Din4	Digital input 4
7	Din5	Digital input 5
8	Din6	Digital input 6
9	Din7	Digital input 7
10	Dout0	Digital output 0
11	Dout1	Digital output 1
12	Dout2	Digital output 2
13	Dout3	Digital output 3
<b>X5 Hall and inc. encoder</b>		
1	H1	Hall sensor 1
2	H2	Hall sensor 2
3	H3	Hall sensor 3
4	A	Inc. encoder, A channel
5	/A	Inc. encoder, A channel invert
6	B	Inc. encoder, B channel
7	/B	Inc. encoder, B channel inverted
8	Inx	Inc. encoder, index channel
9	+U5V	5V output voltage for sensor supply
10	GND	Ground for sensor supply (don't connect with system GND)
<b>X6 Motor</b>		
1	Ma	Motor phase A
2	Mb	Motor phase B
3	Mc	Motor phase C
<b>X7 EtherCAT - In port</b>		
<b>X8 EtherCAT - Out port</b>		

# SVTE-A-E55-HC-Profinet Servo Drives

60VDC | 14.5A  
DC motors, BLDC motors

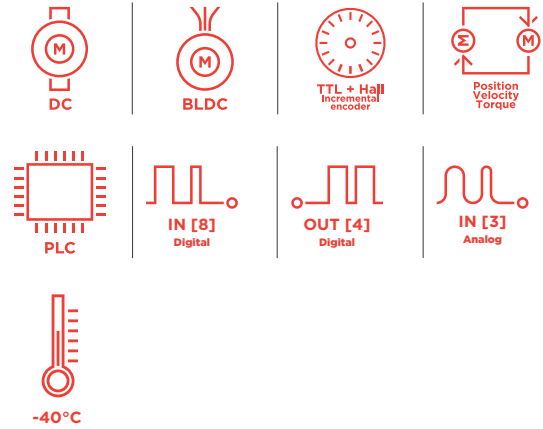
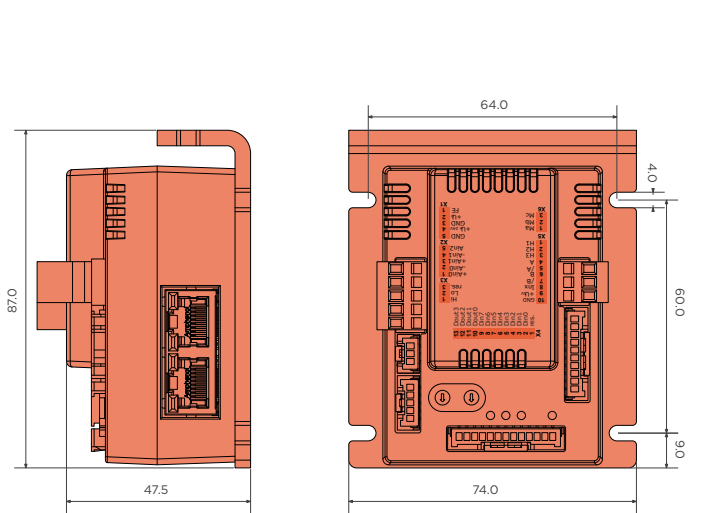

CANopen | PROFINET

Values	Unit
<b>Power</b>	
1 Electronic supply voltage Ue	VDC 9..30
2 Power supply voltage Up	Vdc 9..60
3 Max. output current	A 50
4 Continuous output current	A 14.5
5 Output voltage	Up to 100%
<b>Motor types</b>	
6 DC motors	yes
7 BLDC motors	yes
8 Stepper motors	no
<b>Mechanical</b>	
9 Size LxWxH	mm 78 x 74 x 47
<b>CAN bus</b>	
10 Protocol	DS301
11 Device profile	DS402
12 Galvanically isolated	no
<b>Profinet</b>	
13 Type	Slave
14 Physical layer	100 Base-Tx
15 Max. baudrate	100 Mbit/s
16 Number of ports	2xRJ45 (PORT1,PORT2)
<b>Incremental encoder</b>	
17 Input voltage (24VDC tolerant)	VDC 0..5
18 Signal type	differential, open collector, single ended
<b>Hall sensors</b>	
19 Input voltage	VDC 0.5
20 Signal type	open collector, single ended
<b>Digital input</b>	
21 Number	8 (Din0..7)
<b>Digital output</b>	
22 Number	4 (Dout0..3)
23 Continuous output current	A 0.3
<b>Analog inputs</b>	
24 Number	3 (Ain0..2)
25 Signal type - Ain0...1	+/- 10 V, 12 Bit, differential
26 Signal type - Ain2	0..5 V, 12 Bit, single ended
<b>Environment</b>	
27 Operating temperature	°C -40..+70°C

## Connection

<b>X1 Supply</b>		
1	FE	Functional earth
2	+Up	Power supply voltage
3	GND	Ground for power supply voltage
4	+Ue24V	Electronic supply voltage
5	GND	Ground for electronic supply voltage
<b>X2 Analog Inputs</b>		
1	+Ain0	Analog input 0, positive
2	-Ain0	Analog input 0, negative
3	+Ain1	Analog input 1, positive
4	-Ain1	Analog input 1, negative
5	Ain2	Analog Input 2 (5V)
<b>X3 CAN bus</b>		
1	CAN Hi	CAN High
2	CAN Lo	CAN Low
3	res.	Reserved
<b>X4 Digital inputs/outputs</b>		
1	res.	Reserved
2	Din0	Digital input 0
3	Din1	Digital input 1
4	Din2	Digital input 2
5	Din3	Digital input 3
6	Din4	Digital input 4
7	Din5	Digital input 5
8	Din6	Digital input 6
9	Din7	Digital input 7
10	Dout0	Digital output 0
11	Dout1	Digital output 1
12	Dout2	Digital output 2
13	Dout3	Digital output 3
<b>X5 Hall and inc. encoder</b>		
1	H1	Hall sensor 1
2	H2	Hall sensor 2
3	H3	Hall sensor 3
4	A	Inc. encoder, A channel
5	/A	Inc. encoder, A channel invert
6	B	Inc. encoder, B channel
7	/B	Inc. encoder, B channel inverted
8	Inx	Inc. encoder, index channel
9	+U5V	5V output voltage for sensor supply
10	GND	Ground for sensor supply (don't connect with system GND)
<b>X6 Motor</b>		
1	Ma	Motor phase A
2	Mb	Motor phase B
3	Mc	Motor phase C
<b>X7 Profinet - In port</b>		
<b>X8 Profinet - Out port</b>		

# SVTE-A-E60-CanOpen Servo Drives

60VDC | 5A  
DC motors, BLDC motors

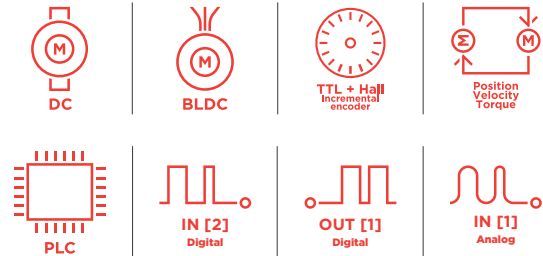
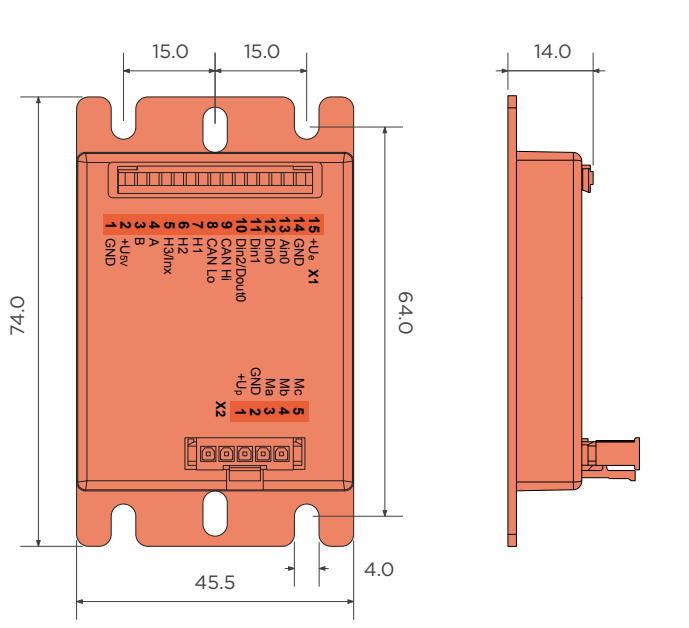

CANopen

Values	Unit
<b>Power</b>	
1 Electronic supply voltage U <sub>e</sub>	VDC 9..30
2 Power supply voltage U <sub>p</sub>	VDC 9..60
3 Max. output current	A 15
4 Continuous output current @ U <sub>p</sub> =24VDC	A 5
5 Continuous output current @ U <sub>p</sub> =48VDC	A 4.3
6 Output voltage	Up to 90%
<b>Motor types</b>	
7 DC motors	yes
8 BLDC motors	yes
9 Stepper motors	no
<b>Mechanical</b>	
10 Size LxWxH	mm 74 x 45.5 x 14
<b>CAN bus</b>	
11 Protocol	DS301
12 Device profile	DS402
13 Galvanically isolated	no
<b>Incremental encoder</b>	
14 Input voltage	VDC 0..5
15 Signal type	open collector, single ended
<b>Hall sensor</b>	
16 Input voltage	VDC 0..5
17 Signal type	open collector, single ended
<b>Digital input</b>	
18 Number (+/-30VDC tolerant)	2 (Din0..1)
19 Number (0..30VDC tolerant)	1 (Din2); Din2 parallel with Dout0 (must not exceed electronic supply voltage)
<b>Digital output</b>	
20 Number	1 (Dout0); Dout0 parallel with Din2
21 Continuous output current	A 1.5 (Load: resistive, inductive)
<b>Analog inputs</b>	
22 Number	1 (Ain0)
23 Signal type	0..10 VDC, 12 Bit, single ended
<b>Environment</b>	
24 Operating temperature	°C -25...+70



## Connection

X1 Hall, inc. encoder, I/O's and CAN		
1	GND	Ground of the auxiliary voltage (don't connect with system GND)
2	+U5V	5V output voltage for sensor supply Sensors: encoder, hall
3	B	Inc. encoder, B channel
4	A	Inc. encoder, A channel
5	H3/Inx	Hall sensor 3 / Inc. encoder, index channel
6	H2	Hall sensor 2
7	H1	Hall sensor 1
8	CAN Lo	CAN Low
9	CAN Hi	CAN High
10	Din2/Dout0	Digital input 2 / Digital output 0
11	Din1	Digital input 1
12	Din0	Digital input 0
13	Ain0	Analog input 0
14	GND	Ground for electronic supply voltage
15	+Ue	Electronic supply voltage
X2 Motor		
1	+Up	Power supply voltage
2	GND	Ground for sensor supply
3	Ma	Motor phase A
4	Mb	Motor phase B
5	Mc	Motor phase C

# SVTE-A-E60-EtherCAT Servo Drives

60VDC | 5A  
DC motors, BLDC motors

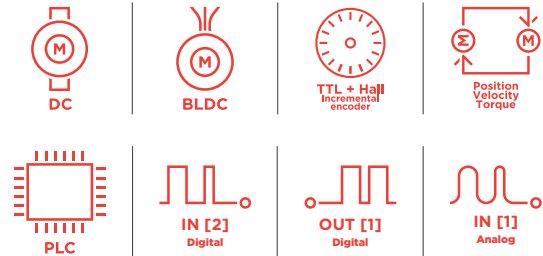
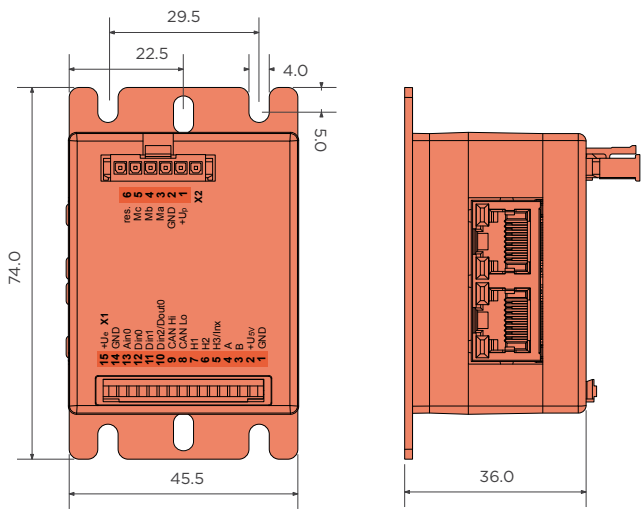

CANopen | EtherCAT

Values	Unit
<b>Power</b>	
1 Electronic supply voltage Ue	VDC 9..30
2 Power supply voltage Up	VDC 9..60
3 Max. output current	A 15
4 Continuous output current @ Up=24VDC	A 5
5 Continuous output current @ Up=48VDC	A 4.3
6 Output voltage	Up to 90%
<b>Motor types</b>	
7 DC motors	yes
8 BLDC motors	yes
9 Stepper motors	no
<b>Mechanical</b>	
10 Size LxWxH	mm 74 x 45.5 x 36
<b>CAN bus</b>	
11 Protocol	DS301
12 Device profile	DS402
13 Galvanically isolated	no
<b>EtherCAT</b>	
14 Type	EtherCAT Slave
15 Physical layer	100 Base-Tx EtherCAT
16 Max. baudrate	100 Mbit/s
17 Number of ports	2xRJ45 (In,Out)
18 Protocol	CoE (CANopen over EtherCAT)
<b>Incremental encoder</b>	
19 Input voltage	VDC 0..5
20 Signal type	open collector, single ended
<b>Hall sensors</b>	
21 Input voltage	VDC 0..5
22 Signal type	open collector, single ended
<b>Digital input</b>	
23 Number (+/-30VDC tolerant)	2 (Din0..1)
24 Number (0..30VDC tolerant)	1 (Din2); Din2 parallel with Dout0 (must not exceed electronic supply voltage)
<b>Digital output</b>	
25 Number	1 (Dout0); Dout0 parallel with Din2
26 Continuous output current	A 1.5 (Load: resistive, inductive)
<b>Analog inputs</b>	
27 Number	1 (Ain0)
28 Signal type	0..10 VDC, 12 Bit, single ended
<b>Environment</b>	
29 Operating temperature	°C -25...+70

## Connection

<b>X1 Hall, inc. encoder, I/O's and CAN</b>		
1	GND	Ground of the auxiliary voltage (don't connect with system GND)
2	+U5V	5V output voltage for sensor supply Sensors: encoder, hall
3	B	Inc. encoder, B channel
4	A	Inc. encoder, A channel
5	H3/Inx	Hall sensor 3 / Inc. encoder, index channel
6	H2	Hall sensor 2
7	H1	Hall sensor 1
8	CAN Lo	CAN Low
9	CAN Hi	CAN High
10	Din2/Dout0	Digital input 2 / Digital output 0
11	Din1	Digital input 1
12	Din0	Digital input 0
13	Ain0	Analog input 0
14	GND	Ground for electronic supply voltage
15	+Ue	Electronic supply voltage
<b>X2 Motor</b>		
1	+Up	Power supply voltage
2	GND	Ground for sensor supply
3	Ma	Motor phase A
4	Mb	Motor phase B
5	Mc	Motor phase C
6	res.	Reserved
<b>X3 EtherCAT - In port</b>		
<b>X4 EtherCAT - Out port</b>		

# SVTE-A-E65-CanOpen Servo Drives

60VDC | 5A  
DC motors, BLDC motors

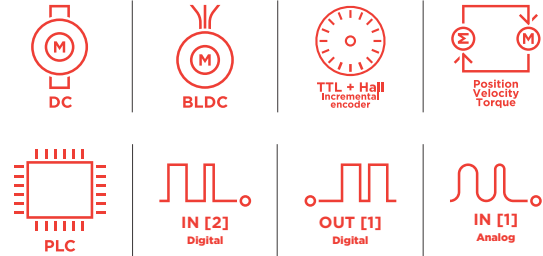
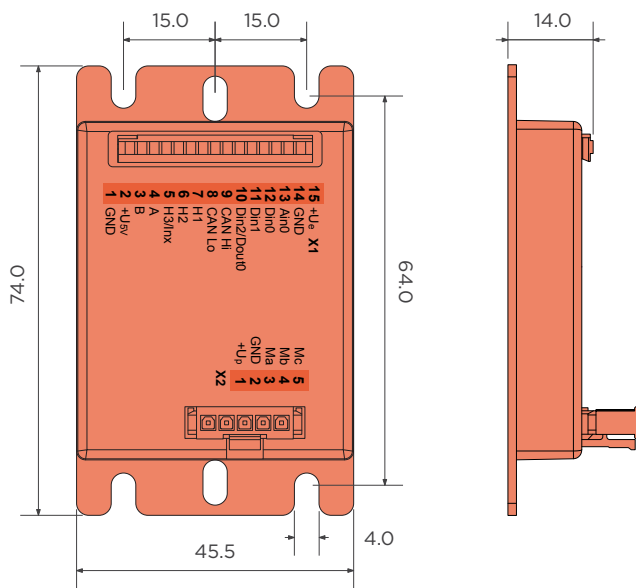

CANopen

Values	Unit
<b>Power</b>	
1 Electronic supply voltage Ue	VDC 9..30
2 Power supply voltage Up	VDC 9..60
3 Max. output current	A 15
4 Continuous output current @ Up=24VDC	A 5
5 Continuous output current @ Up=48VDC	A 4.3
6 Output voltage	Up to 100%
<b>Motor types</b>	
7 DC motors	yes
8 BLDC motors	yes
9 Stepper motors	no
<b>Mechanical</b>	
10 Size LxWxH	mm 74 x 45.5 x 14
<b>CAN bus</b>	
11 Protocol	DS301
12 Device profile	DS402
13 Galvanically isolated	no
<b>Incremental encoder</b>	
14 Input voltage	VDC 0..5
15 Signal type	open collector, single ended
<b>Hall sensors</b>	
16 Input voltage	VDC 0..5
17 Signal type	open collector, single ended
<b>Digital input</b>	
18 Number	2 (Din0..1)
19 Number (0..30VDC tolerant)	1 (Din2); Din2 parallel with Dout0 (must not exceed electronic supply voltage)
<b>Digital output</b>	
20 Number	1 (Dout0); Dout0 parallel with Din2
21 Continuous output current	A 1.5 (Load: resistive, inductive)
<b>Analog inputs</b>	
22 Number	1 (Ain0)
23 Signal type	+/- 10 VDC, 12 Bit, single ended
<b>Environment</b>	
24 Operating temperature	°C -25...+70

## Connection

### X1 Hall, inc. encoder, I/O's and CAN

1	GND	Ground of the auxiliary voltage (don't connect with system GND)
2	+U5V	5V output voltage for sensor supply Sensors: encoder, hall
3	B	Inc. encoder, B channel
4	A	Inc. encoder, A channel
5	H3/Inx	Hall sensor 3 / Inc. encoder, index channel
6	H2	Hall sensor 2
7	H1	Hall sensor 1
8	CAN Lo	CAN Low
9	CAN Hi	CAN High
10	Din2/Dout0	Digital input 2 / Digital output 0
11	Din1	Digital input 1
12	Din0	Digital input 0
13	Ain0	Analog input 0
14	GND	Ground for electronic supply voltage
15	+Ue	Electronic supply voltage

### X2 Motor

1	+Up	Power supply voltage
2	GND	Ground for sensor supply
3	Ma	Motor phase A
4	Mb	Motor phase B
5	Mc	Motor phase C

# SVTE-A-E65-EtherCAT Servo Drives

60VDC | 5A  
DC motors, BLDC motors

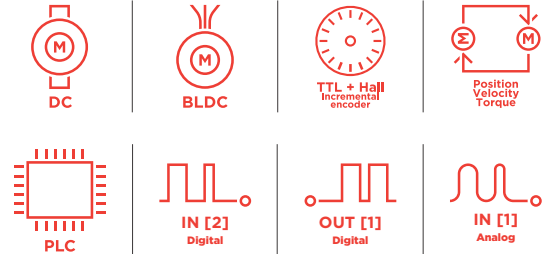
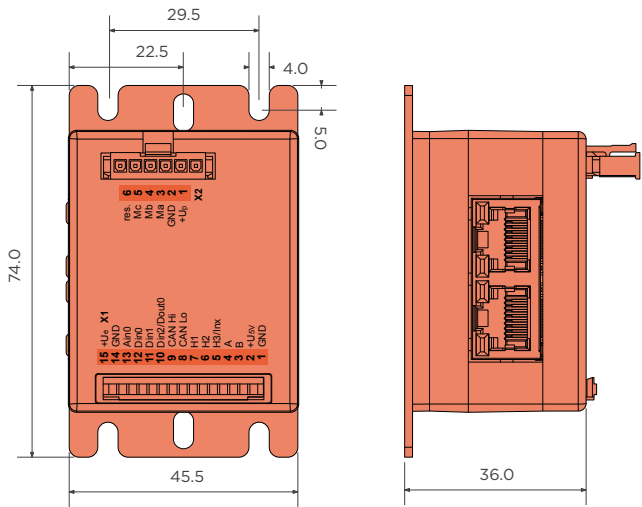

CANopen | EtherCAT

Values	Unit
<b>Power</b>	
1 Electronic supply voltage Ue	VDC 9..30
2 Power supply voltage Up	VDC 9..60
3 Max. output current	A 15
4 Continuous output current @ Up=24VDC	A 5
5 Continuous output current @ Up=48VDC	A 4.3
6 Output voltage	Up to 100%
<b>Motor types</b>	
7 DC motors	yes
8 BLDC motors	yes
9 Stepper motors	no
<b>Mechanical</b>	
10 Size LxWxH	mm 74 x 45.5 x 36
<b>CAN bus</b>	
11 Protocol	DS301
12 Device profile	DS402
13 Galvanically isolated	no
<b>EtherCAT</b>	
14 Type	EtherCAT Slave
15 Physical layer	100 Base-Tx EtherCAT
16 Max. baudrate	100 Mbit/s
17 Number of ports	2xRJ45 (In,Out)
18 Protocol	CoE (CANopen over EtherCAT)
<b>Incremental encoder</b>	
19 Input voltage	VDC 0..5
20 Signal type	open collector, single ended
<b>Hall sensors</b>	
21 Input voltage	VDC 0..5
22 Signal type	open collector, single ended
<b>Digital input</b>	
23 Number	2 (Din0..1)
24 Number (0..30VDC tolerant)	1 (Din2); Din2 parallel with Dout0 (must not exceed electronic supply voltage)
<b>Digital output</b>	
25 Number	1 (Dout0); Dout0 parallel with Din2
26 Continuous output current	A 1.5 (Load: resistive, inductive)
<b>Analog inputs</b>	
27 Number	1 (Ain0)
28 Signal type	+/- 0..10 VDC, 12 Bit, single ended
<b>Environment</b>	
29 Operating temperature	°C -25...+70

## Connection

### X1 Hall, inc. encoder, I/O's and CAN

1	GND	Ground of the auxiliary voltage (don't connect with system GND)
2	+U5V	5V output voltage for sensor supply Sensors: encoder, hall
3	B	Inc. encoder, B channel
4	A	Inc. encoder, A channel
5	H3/Inx	Hall sensor 3 / Inc. encoder, index channel
6	H2	Hall sensor 2
7	H1	Hall sensor 1
8	CAN Lo	CAN Low
9	CAN Hi	CAN High
10	Din2/Dout0	Digital input 2 / Digital output 0
11	Din1	Digital input 1
12	Din0	Digital input 0
13	Ain0	Analog input 0
14	GND	Ground for electronic supply voltage
15	+Ue	Electronic supply voltage

### X2 Motor

1	+Up	Power supply voltage
2	GND	Ground for sensor supply
3	Ma	Motor phase A
4	Mb	Motor phase B
5	Mc	Motor phase C
6	res.	Reserved

### X3 EtherCAT - In port

### X4 EtherCAT - Out port

# SVTE-A-E65-Profinet Servo Drives

60VDC | 5A  
DC motors, BLDC motors

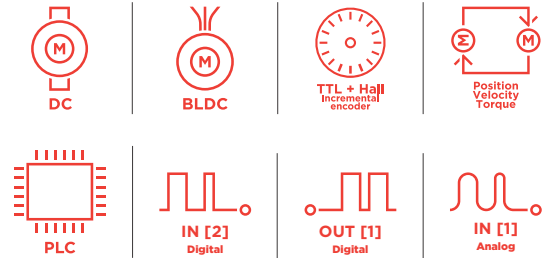
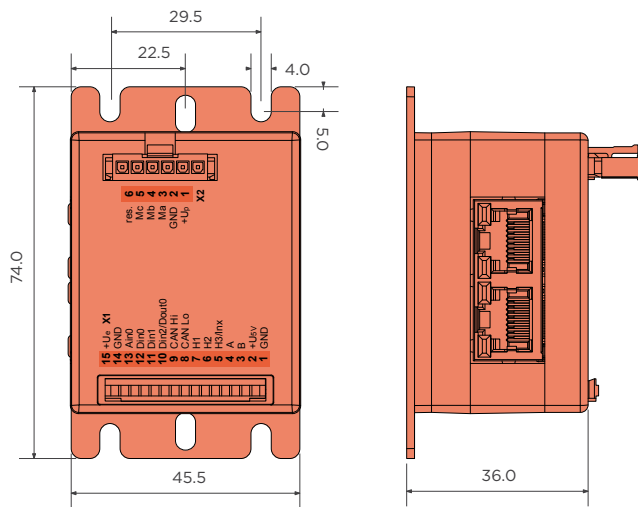

CANopen | PROFIBUS NET

Values	Unit
<b>Power</b>	
1 Electronic supply voltage Ue	VDC 9..30
2 Power supply voltage Up	VDC 9..60
3 Max. output current	A 15
4 Continuous output current @ Up=24VDC	A 5
5 Continuous output current @ Up=48VDC	A 4.3
6 Output voltage	Up to 100%
<b>Motor types</b>	
7 DC motors	yes
8 BLDC motors	yes
9 Stepper motors	no
<b>Mechanical</b>	
10 Size LxWxH	mm 74 x 45.5 x 36
<b>CAN bus</b>	
11 Protocol	DS301
12 Device profile	DS402
13 Galvanically isolated	no
<b>Profinet</b>	
14 Type	Slave
15 Physical layer	100 Base-Tx
16 Max. baudrate	100 Mbit/s
17 Number of ports	2xRJ45 (PORT1, PORT2)
<b>Incremental encoder</b>	
18 Input voltage	VDC 0..5
19 Signal type	open collector, single ended
<b>Hall sensors</b>	
20 Input voltage	VDC 0..5
21 Signal type	open collector, single ended
<b>Digital input</b>	
22 Number	2 (Din0..1)
23 Number (0..30Vdc tolerant)	1 (Din2); Din2 parallel with Dout0 (must not exceed electronic supply voltage)
<b>Digital output</b>	
24 Number	1 (Dout0); Dout0 parallel with Din2
25 Continuous output current	A 1.5 (Load: resistive, inductive)
<b>Analog inputs</b>	
26 Number	1 (Ain0)
27 Signal type	+/- 10 Vdc, 12 Bit, single ended
<b>Environment</b>	
28 Operating temperature	°C -25...+70



## Connection

<b>X1 Hall, inc. encoder, I/O's and CAN</b>		
1	GND	Ground of the auxiliary voltage (don't connect with system GND)
2	+U5V	5V output voltage for sensor supply Sensors: encoder, hall
3	B	Inc. encoder, B channel
4	A	Inc. encoder, A channel
5	H3/Inx	Hall sensor 3 / Inc. encoder, index channel
6	H2	Hall sensor 2
7	H1	Hall sensor 1
8	CAN Lo	CAN Low
9	CAN Hi	CAN High
10	Din2/Dout0	Digital input 2 / Digital output 0
11	Din1	Digital input 1
12	Din0	Digital input 0
13	Ain0	Analog input 0
14	res.	Reserved
15	+Ue	Electronic supply voltage
<b>X2 Motor</b>		
1	+Up	Power supply voltage
2	GND	Ground for sensor supply
3	Ma	Motor phase A
4	Mb	Motor phase B
5	Mc	Motor phase C
6	res.	Reserved
<b>X3 Profinet - PORT1</b>		
<b>X4 Profinet - PORT2</b>		

# SVTE-A-E67-CanOpen Servo Drives

60VDC | 5A  
DC motors, BLDC motors

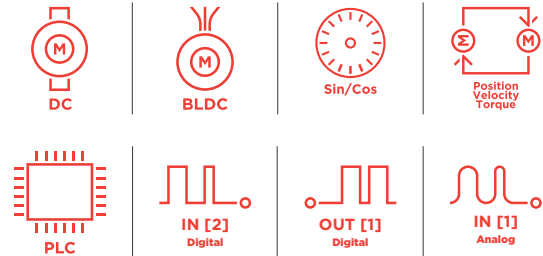
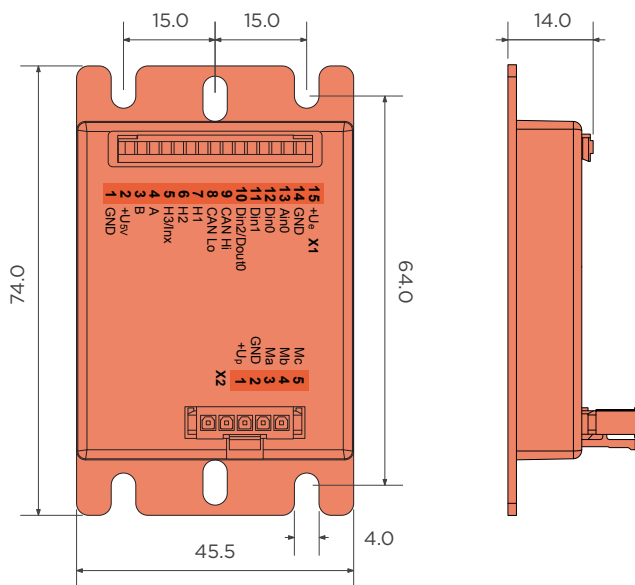

**CANopen**

Values	Unit
<b>Power</b>	
1 Electronic supply voltage Ue	VDC 9..30
2 Power supply voltage Up	VDC 9..60
3 Max. output current	A 15
4 Continuous output current @ Up=24VDC	A 5
5 Continuous output current @ Up=48VDC	A 4.3
6 Output voltage	Up to 100%
<b>Motor types</b>	
7 DC motors	yes
8 BLDC motors	yes
9 Stepper motors	no
<b>Mechanical</b>	
10 Size LxWxH	mm 74 x 45.5 x 14
<b>CAN bus</b>	
11 Protocol	DS301
12 Device profile	DS402
13 Galvanically isolated	no
<b>Encoder</b>	
14 Input voltage (24VDC tolerant)	1 V peak-peak, differential
15 Signal type	sin / cos, analog, differential
16 Resolution	13 bit per sine period
<b>Digital input</b>	
17 Number	2 (Din0..1)
18 Number (0..30Vdc tolerant)	1 (Din2); Din2 parallel with Dout0 (must not exceed electronic supply voltage)
<b>Digital output</b>	
19 Number	1 (Dout0); Dout0 parallel with Din2
20 Continuous output current	A 1.5 (Load: resistive, inductive)
<b>Analog inputs</b>	
21 Number	1 (Ain0)
22 Signal type	+/- 10 VDC, 12 Bit, single ended
<b>Environment</b>	
23 Operating temperature	°C -25...+70

## Connection

X1 Encoder, I/O's and CAN		
1	GND	Ground of the auxiliary voltage (don't connect with system GND)
2	+U5V	5V output voltage for sensor supply Sensors
3	+Cos	Cosine + signal
4	+Sin	Sine + signal
5	res.	Reserved
6	-Cos	Cosine - signal
7	-Sin	Sine - signal
8	CAN Lo	CAN Low
9	CAN Hi	CAN High
10	Din2/Dout0	Digital input 2 / Digital output 0
11	Din1	Digital input 1
12	Din0	Digital input 0
13	Ain0	Analog input 0
14	GND	Ground for electronic supply voltage
15	+Ue	Electronic supply voltage
X2 Motor		
1	+Up	Power supply voltage
2	GND	Ground for sensor supply
3	Ma	Motor phase A
4	Mb	Motor phase B
5	Mc	Motor phase C

# SVTE-A-E67-EtherCAT Servo Drives

60VDC | 5A  
DC motors, BLDC motors

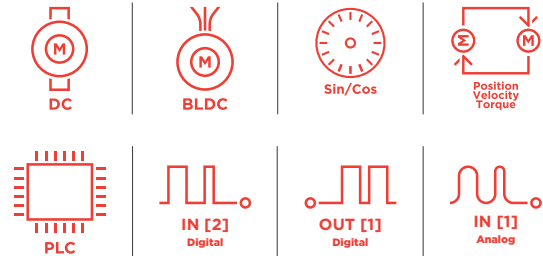
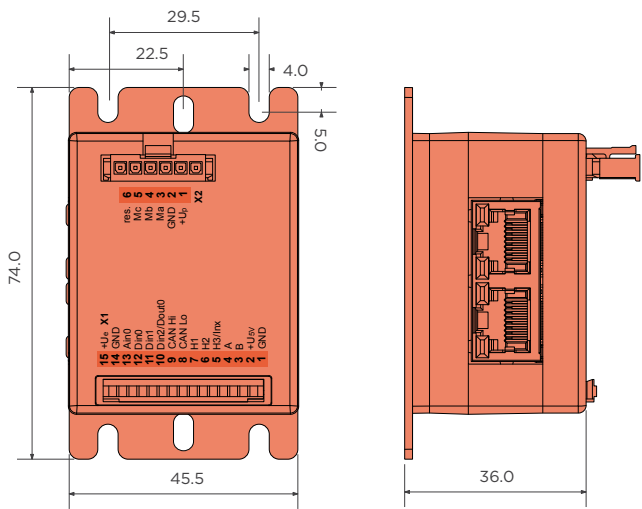

CANopen | EtherCAT

Values	Unit
<b>Power</b>	
1 Electronic supply voltage Ue	VDC 9..30
2 Power supply voltage Up	VDC 9..60
3 Max. output current	A 15
4 Continuous output current @ Up=24VDC	A 5
5 Continuous output current @ Up=48VDC	A 4.3
6 Output voltage	Up to 100%
<b>Motor types</b>	
7 DC motors	yes
8 BLDC motors	yes
9 Stepper motors	no
<b>Mechanical</b>	
10 Size LxWxH	mm 74 x 45.5 x 36
<b>CAN bus</b>	
11 Protocol	DS301
12 Device profile	DS402
13 Galvanically isolated	no
<b>EtherCAT</b>	
14 Type	EtherCAT Slave
15 Physical layer	100 Base-Tx EtherCAT
16 Max. baudrate	100 Mbit/s
17 Number of ports	2xRJ45 (In,Out)
18 Protocol	CoE (CANopen over EtherCAT)
<b>Encoder</b>	
19 Input voltage (24VDC tolerant)	1 V peak-peak, differential
20 Signal type	sin/cos, analog, differential
21 Resolution	13 bit per sine period
<b>Digital input</b>	
22 Number	2 (Din0..1)
23 Number (0..30VDC tolerant)	1 (Din2); Din2 parallel with Dout0 (must not exceed electronic supply voltage)
<b>Digital output</b>	
24 Number	1 (Dout0); Dout0 parallel with Din2
25 Continuous output current	A 1.5 (Load: resistive, inductive)
<b>Analog inputs</b>	
26 Number	1 (Ain0)
27 Signal type	+/- 10 VDC, 12 Bit, single ended
<b>Environment</b>	
27 Operating temperature	°C -25...+70

## Connection

X1 Encoder, I/O's and CAN		
1	GND	Ground of the auxiliary voltage (don't connect with system GND)
2	+U5V	5V output voltage for sensor supply Sensors
3	+Cos	Cosine + signal
4	+Sin	Sine + signal
5	res.	Reserved
6	-Cos	Cosine - signal
7	-Sin	Sine - signal
8	CAN Lo	CAN Low
9	CAN Hi	CAN High
10	Din2/Dout0	Digital input 2 / Digital output 0
11	Din1	Digital input 1
12	Din0	Digital input 0
13	Ain0	Analog input 0
14	GND	Ground for electronic supply voltage
15	+Ue	Electronic supply voltage
X2 Motor		
1	+Up	Power supply voltage
2	GND	Ground for sensor supply
3	Ma	Motor phase A
4	Mb	Motor phase B
5	Mc	Motor phase C
6	res.	Reserved
X3 EtherCAT - In port		
X4 EtherCAT - Out port		

# SVTE-A-E67-Profinet Servo Drives

60VDC | 5A  
DC motors, BLDC motors

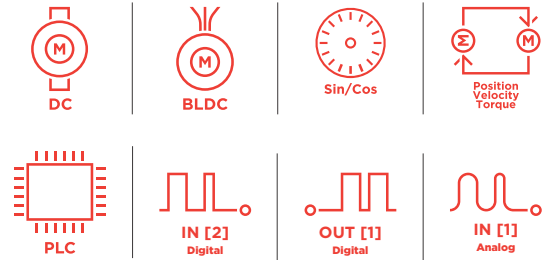
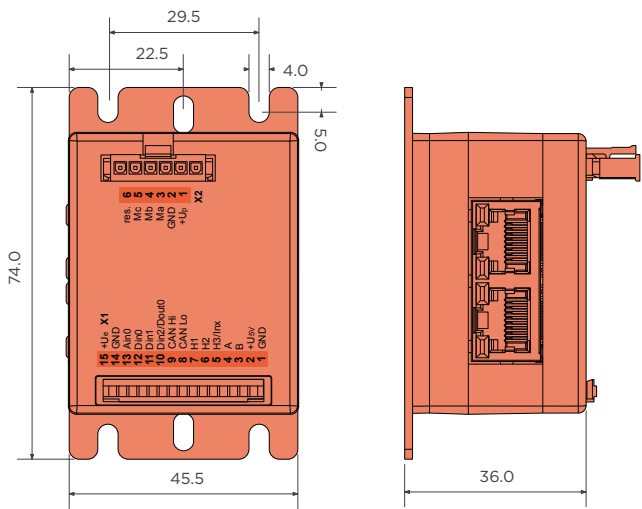

CANopen | PROFIBUS NET

Values	Unit
<b>Power</b>	
1 Electronic supply voltage Ue	VDC 9..30
2 Power supply voltage Up	VDC 9..60
3 Max. output current	A 15
4 Continuous output current @ Up=24VDC	A 5
5 Continuous output current @ Up=48VDC	A 4.3
6 Output voltage	Up to 100%
<b>Motor types</b>	
7 DC motors	yes
8 BLDC motors	yes
9 Stepper motors	no
<b>Mechanical</b>	
10 Size LxWxH	mm 74 x 45.5 x 36
<b>CAN bus</b>	
11 Protocol	DS301
12 Device profile	DS402
13 Galvanically isolated	no
<b>Profinet</b>	
14 Type	Slave
15 Physical layer	100 Base-Tx
16 Max. baudrate	100 Mbit/s
17 Number of ports	2xRJ45 (PORT1, PORT2)
<b>Encoder</b>	
18 Input voltage (24VDC tolerant)	1 V peak-peak, differential
19 Signal type	sin/cos, analog, differential
20 Resolution	13 bit per sine period
<b>Digital input</b>	
21 Number	2 (Din0..1)
22 Number (0..30VDC tolerant)	1 (Din2); Din2 parallel with Dout0 (must not exceed electronic supply voltage)
<b>Digital output</b>	
23 Number	1 (Dout0); Dout0 parallel with Din2
24 Continuous output current	A 1.5 (Load: resistive, inductive)
<b>Analog inputs</b>	
25 Number	1 (Ain0)
26 Signal type	+/- 10 VDC, 12 Bit, single ended
<b>Environment</b>	
26 Operating temperature	°C -25...+70

## Connection

X1 Encoder, I/O's and CAN		
1	GND	Ground of the auxiliary voltage (don't connect with system GND)
2	+U5V	5V output voltage for sensor supply Sensors
3	+Cos	Cosine + signal
4	+Sin	Sine + signal
5	res.	Reserved
6	-Cos	Cosine - signal
7	-Sin	Sine - signal
8	CAN Lo	CAN Low
9	CAN Hi	CAN High
10	Din2/Dout0	Digital input 2 / Digital output 0
11	Din1	Digital input 1
12	Din0	Digital input 0
13	Ain0	Analog input 0
14	GND	Ground for electronic supply voltage
15	+Ue	Electronic supply voltage
X2 Motor		
1	+Up	Power supply voltage
2	GND	Ground for sensor supply
3	Ma	Motor phase A
4	Mb	Motor phase B
5	Mc	Motor phase C
6	res.	Reserved
X3 Profinet - In port		
X4 Profinet - Out port		

# SVTE-A-S40-CanOpen Stepper Drives

60VDC | 7A  
Stepper motors

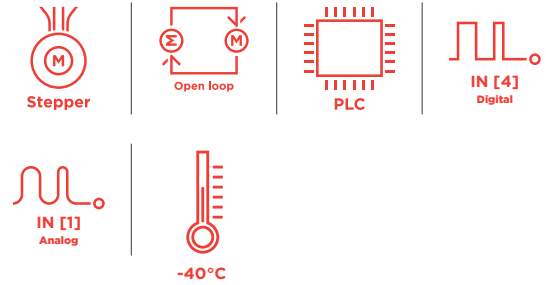
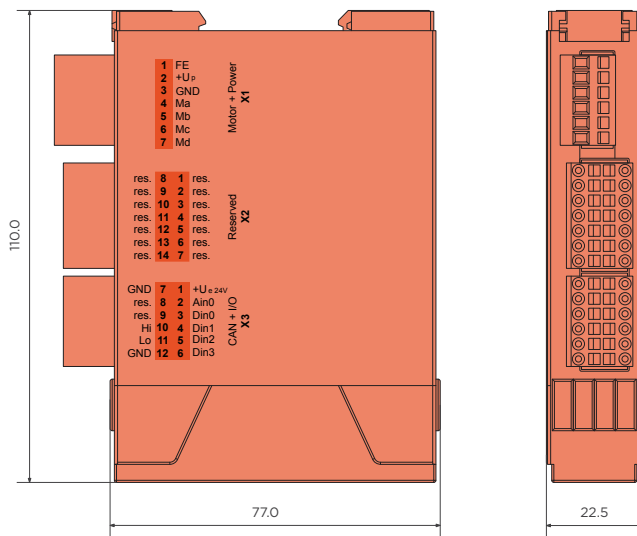

CANopen

Values	Unit
<b>Power</b>	
1 Electronic supply voltage U <sub>e</sub>	VDC 9..30
2 Power supply voltage U <sub>p</sub>	VDC 9..60
3 Max. output current	A 20
4 Continuous output current @ U <sub>p</sub> =24VDC	A 7
5 Continuous output current @ U <sub>p</sub> =48VDC	A 6
6 Output voltage	Up to 85%
<b>Motor types</b>	
7 DC motors	no
8 BLDC motors	no
9 Stepper motors	yes
<b>Mechanical</b>	
10 Size LxWxH	mm 110 x 22.5 x 77
<b>CAN bus</b>	
11 Protocol	DS301
12 Device profile	DS402
13 Galvanically isolated	no
<b>Digital input</b>	
14 Number	4 (Din0..3)
<b>Analog inputs</b>	
15 Number	1 (Ain0)
16 Signal type	0..10 VDC, 12 Bit, single ended
<b>Environment</b>	
17 Operating temperature	°C -40...+70



## Connection

X1 Motor		
1	FE	Functional earth
2	+Up	Power supply voltage
3	GND	Ground for sensor supply
4	Ma	Motor phase A
5	Mb	Motor phase B
6	Mc	Motor phase C
7	Md	Motor phase D
X2 Reserved		
1	res.	Reserved
2	res.	Reserved
3	res.	Reserved
4	res.	Reserved
5	res.	Reserved
6	res.	Reserved
7	+U5V	5V output voltage for sensor supply (auxiliary voltage)
8	res.	Reserved
9	res.	Reserved
10	res.	Reserved
11	res.	Reserved
12	res.	Reserved
13	res.	Reserved
14	GND	Ground for sensor supply (don't connect with system GND)
X3 I/O's and CAN		
1	+Ue24V	Electronic supply voltage
2	Ain0	Analog input 0
3	Din0	Digital input 0
4	Din1	Digital input 1
5	Din2	Digital input 2
6	Din3	Digital input 3
7	GND	Ground for electronic supply voltage
8	res.	Reserved
9	res.	Reserved
10	CAN Hi	CAN High
11	CAN Lo	CAN Low
12	CAN GND	CAN Ground

# SVTE-A-S45-CanOpen Stepper Drives

60VDC | 7A  
Stepper motors

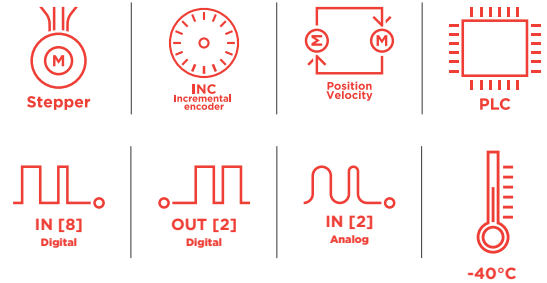
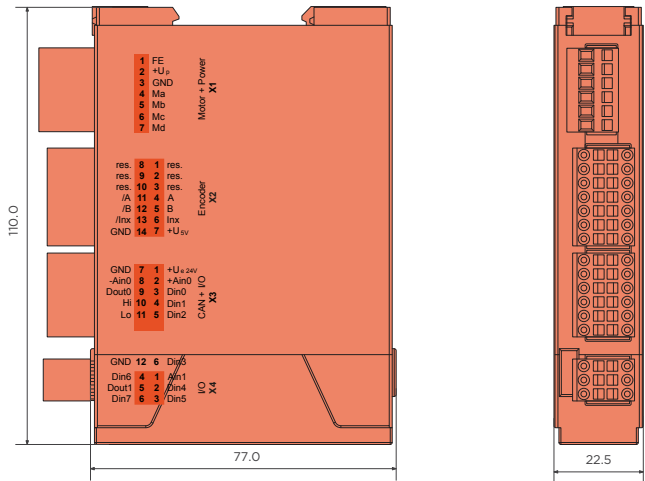

CANopen

Values	Unit
<b>Power</b>	
1 Electronic supply voltage U <sub>e</sub>	VDC 9..30
2 Power supply voltage U <sub>p</sub>	VDC 9..60
3 Max. output current	A 20
4 Continuous output current @ U <sub>p</sub> =24VDC	A 7
5 Continuous output current @ U <sub>p</sub> =48VDC	A 6
6 Output voltage	Up to 85%
<b>Motor types</b>	
7 DC motors	no
8 BLDC motors	no
9 Stepper motors	yes
<b>Mechanical</b>	
10 Size LxWxH	mm 110 x 22.5 x 77
<b>CAN bus</b>	
11 Protocol	DS301
12 Device profile	DS402
13 Galvanically isolated	no
<b>Incremental encoder</b>	
14 Input voltage (24VDC tolerant)	VDC 0..5
15 Signal type	open collector, single ended, differential
<b>Digital input</b>	
16 Number	8 (Din0..7)
<b>Digital output</b>	
17 Number	2 (Dout0..Dout1)
18 Continuous output current	A 1.5 (Load: resistive, inductive)
<b>Analog inputs</b>	
19 Number	2 (Ain0..1)
20 Signal type - Ain0	+/- 10 VDC, 12 Bit, differential
21 Signal type - Ain1	+/- 10 VDC, 12 Bit, single ended
<b>Environment</b>	
22 Operating temperature	°C -40...+70

## Connection

X1 Motor		
1	FE	Functional earth
2	+Up	Power supply voltage
3	GND	Ground for sensor supply
4	Ma	Motor phase A
5	Mb	Motor phase B
6	Mc	Motor phase C
7	Md	Motor phase D
X2 Inc. encoder		
1	res.	Reserved
2	res.	Reserved
3	res.	Reserved
4	A	Inc. encoder, A channel
5	B	Inc. encoder, B channel
6	Inx	Inc. encoder, index channel
7	+U5V	5V output voltage for sensor supply: encoder
8	res.	Reserved
9	res.	Reserved
10	res.	Reserved
11	/A	Inc. encoder, A channel inverted
12	/B	Inc. encoder, B channel inverted
13	/Inx	Inc. encoder, index channel inverted
14	GND	Ground for sensor supply (don't connect with system GND)
X3 I/O's and CAN		
1	+Ue24V	Electronic supply voltage
2	+Ain0	Analog input 0, positive
3	Din0	Digital input 0
4	Din1	Digital input 1
5	Din2	Digital input 2
6	Din3	Digital input 3
7	GND	Ground for electronic supply voltage
8	-Ain0	Analog input 0, negative
9	Dout0	Digital output 0
10	CAN Hi	CAN High
11	CAN Lo	CAN Low
12	CAN GND	CAN Ground
X4 I/O's		
1	Ain1	Analog input 1
2	Din4	Digital input 4
3	Din5	Digital input 5
4	Din6	Digital output 6
5	Dout1	Digital output 1
6	Din7	Digital input 7

# SVTE-A-S60-CanOpen Stepper Drives

60VDC | 3.5A  
Stepper motors

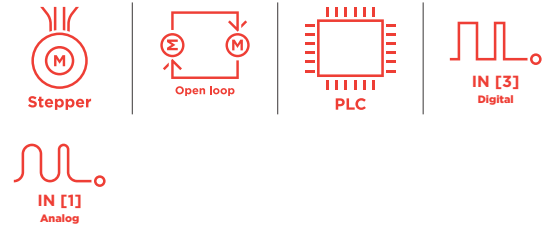
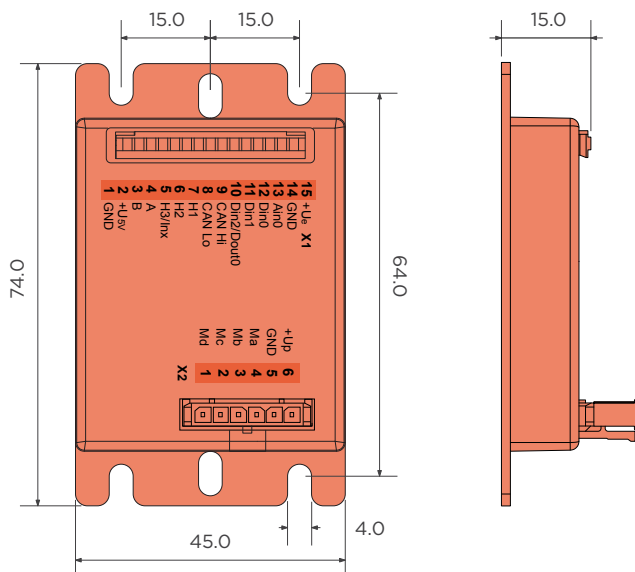

**CANopen**

Values	Unit
<b>Power</b>	
1 Electronic supply voltage Ue	VDC 9..30
2 Power supply voltage Up	VDC 9..60
3 Max. output current	A 10
4 Continuous output current @ Up=24VDC	A 3.5
5 Continuous output current @ Up=48VDC	A 3
6 Output voltage	Up to 85%
<b>Motor types</b>	
7 DC motors	no
8 BLDC motors	no
9 Stepper motors	yes
<b>Mechanical</b>	
10 Size LxWxH	mm 74 x 45.5 x 14
<b>CAN bus</b>	
11 Protocol	DS301
12 Device profile	DS402
13 Galvanically isolated	no
<b>Digital input</b>	
14 Number	3 (Din0..2)
<b>Analog inputs</b>	
15 Number	1 (Ain0)
16 Signal type	0..10 VDC, 12 Bit, single ended
<b>Environment</b>	
17 Operating temperature	°C -25...+70

## Connection

### X3 I/O's and CAN

1	GND	Ground of the auxiliary voltage (don't connect with system GND)
2	+U5V	5V output voltage (auxiliary voltage)
3	res.	Reserved
4	res.	Reserved
5	res.	Reserved
6	res.	Reserved
7	res.	Reserved
8	CAN Lo	CAN Low
9	CAN Hi	CAN High
10	Din2	Digital input 2
11	Din1	Digital input 1
12	Din0	Digital input 0
13	Ain0	Analog input 0
14	GND	Ground for electronic supply voltage
15	+Ue	Electronic supply voltage

### X2 Motor

1	+Up	Power supply voltage
2	GND	Ground for sensor supply
3	Ma	Motor phase A
4	Mb	Motor phase B
5	Mc	Motor phase C
6	Md	Motor phase D

# SVTE-A-S65-CanOpen Stepper Drives

60VDC | 3.5A  
Stepper motors

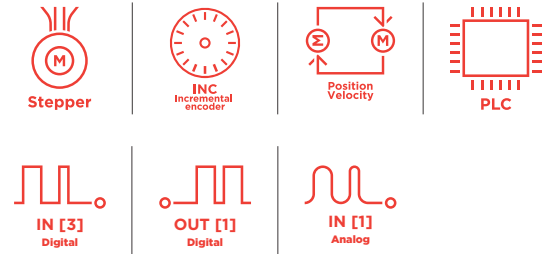
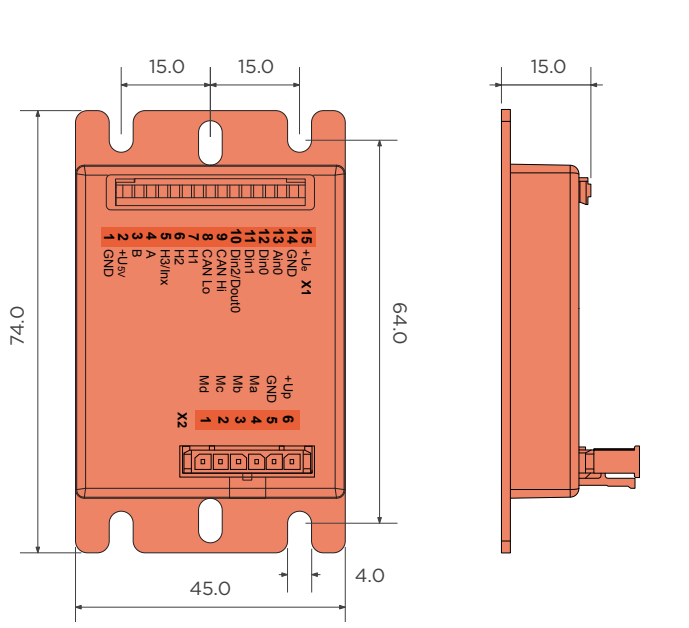

CANopen

Values	Unit
<b>Power</b>	
1 Electronic supply voltage Ue	VDC 9..30
2 Power supply voltage Up	VDC 9..60
3 Max. output current	A 10
4 Continuous output current @ Up=24VDC	A 3.5
5 Continuous output current @ Up=48VDC	A 3
6 Output voltage	Up to 85%
<b>Motor types</b>	
7 DC motors	no
8 BLDC motors	no
9 Stepper motors	yes
<b>Mechanical</b>	
10 Size LxWxH	mm 74 x 45.5 x 14
<b>CAN bus</b>	
11 Protocol	DS301
12 Device profile	DS402
13 Galvanically isolated	no
<b>Incremental encoder</b>	
14 Input voltage	VDC 0..5
15 Signal type	open collector, single ended
<b>Digital input</b>	
16 Number	3 (Din0..2); Din2 parallel with Dout0 (must not exceed electronic supply voltage)
<b>Digital output</b>	
17 Number	1 (Dout0); Dout0 parallel with Din2
18 Continuous output current	1.5 (Load: resistive, inductive)
<b>Analog inputs</b>	
19 Number	1 (Ain0)
20 Signal type - Ain0	+/- 10 VDC, 12 Bit, single ended
<b>Environment</b>	
22 Operating temperature	°C -25...+70

## Connection

### X3 I/O's and CAN

1	GND	Ground of the auxiliary voltage (don't connect with system GND)
2	+U5V	5V output voltage for supply encoder
3	B	Inc. encoder, B channel
4	A	Inc. encoder, A channel
5	Inx	Inc. encoder, index channel
6	res.	Reserved
7	res.	Reserved
8	CAN Lo	CAN Low
9	CAN Hi	CAN High
10	Din2/Dout0	Digital input 2 / Digital output 0
11	Din1	Digital input 1
12	Din0	Digital input 0
13	Ain0	Analog input 0
14	GND	Ground for electronic supply voltage
15	+Ue	Electronic supply voltage

### X2 Motor

1	+Up	Power supply voltage
2	GND	Ground for sensor supply
3	Ma	Motor phase A
4	Mb	Motor phase B
5	Mc	Motor phase C
6	Md	Motor phase D

# SVTE-4AX-CanOpen

## 4 Axes Servo Drives

48VDC | 5A/Axis  
 BLDC motors, Brushless motors,  
 Stepper Motors, Linear Motors

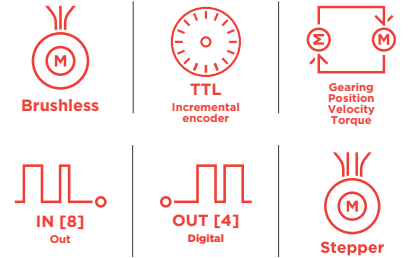
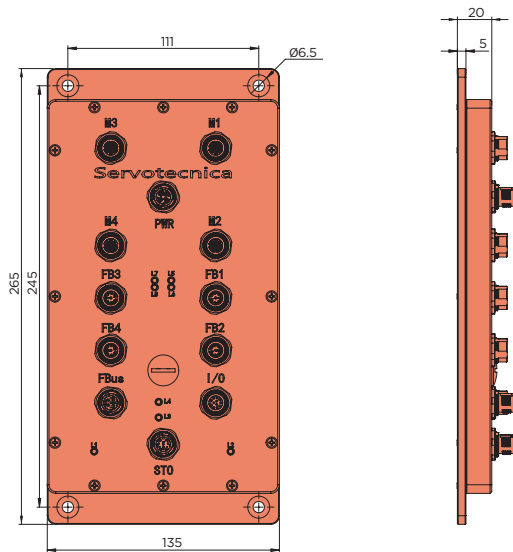

**CANopen**

Values	Unit
<b>Power</b>	
1 Electronic supply voltage Ue	VDC 19..30
2 Power supply voltage Up	VDC 19..60
3 Max. output current	A 10A/axis
4 Continuous output current @ Up=48VVDC	A 5A/axis
5 Output voltage	up to 96%
<b>Motor types</b>	
6 Brushless	yes
7 DC motors	no
8 BLDC motors	yes
9 Stepper motors	yes
<b>Mechanical</b>	
10 Size LxWxH	mm 265x135x20
<b>Communication CAN bus</b>	
11 Protocol	DS301
12 Device profile	DS402
13 Galvanically isolated	yes
<b>Incremental encoder</b>	
14 Input voltage	VDC 0..5
15 Signal type	differential, single ended
<b>Digital input</b>	
16 Number	8 (Din0..7)
<b>Digital output</b>	
17 Number	4 (Dout0..3)
18 Continuous output current	A 0.5 (Load: resistive, inductive)
<b>Environment</b>	
19 Operating temperature	°C 0..50°C



## Connection

M1..M4	BLDC/Brushless	Stepper
1	Temp.Sensor PT1000	Temp.Sensor PT1000
2	Temp.Sensor PT1000	Temp.Sensor PT1000
3	Bk+ Brake +	Bk+ Brake +
4	Bk- Brake -	Bk- Brake -
5	Mb Motor phase B	Mc Motor phase C
6	N.C. Non Connected	Md Motor phase D
7	Ma Motor phase A	Ma Motor phase A
8	Mc Motor phase C	Mb Motor phase B
<b>FB1..FB4</b>	<b>Feedback</b>	
1	+U5V	5V output voltage for sensor supply
2	A	Inc. encoder, A channel
3	/A	Inc. encoder, A channel inverted
4	B	Inc. encoder, B channel
5	/B	Inc. encoder, B channel inverted
6	Inx	Inc. encoder, index channel
7	/Inx	Inc. encoder, index channel inverted
8	GND	Ground for sensor supplychannel inverted
<b>STO</b>	<b>Logic power supply / STO</b>	
1	+Ue24V	Electronic supply voltage
2	GND	Ground for electronic supply voltage
3	N.C.	Non Connected
4	FE	Functional earth
5	STO1	Safety Torque Off 2 +24Vdc
6	STO2	Safety Torque Off 1 +24Vdc
7	STO Com	Safety Torque Com
8	STO Out	Safety Torque Off Output
<b>Fbus</b>	<b>CanBus</b>	
1	CAN Lo	CAN Low
2	N.C.	Non Connected
3	CAN GND	CAN Ground
4	CAN Hi	CAN High
5	CAN GND	CAN Ground
<b>I/O</b>	<b>Digital I/O</b>	
1	Din5	Digital Input 5
2	Din3	Digital Input 3
3	Din2	Digital Input 2
4	Din0	Digital Input 0
5	Dout0	Digital Output 0
6	Dout1	Digital Output 1
7	Dout2	Digital Output 2
8	Dout3	Digital Output 3
9	Din6	Digital Input 6
10	Din4	Digital Input 4
11	Din1	Digital Input 1
12	Din8	Digital Input 8
<b>PWR</b>	<b>Power supply</b>	
1	+Up	Power supply voltage
2	+Up	Power supply voltage
3	GND	Ground for power supply voltage
4	GND	Ground for power supply voltage

# SVTE-4AX-CanOpen

## 4 Axes Servo Drives

48VDC | 5A/Axis  
 BLDC motors, Brushless motors,  
 Stepper Motors, Linear Motors

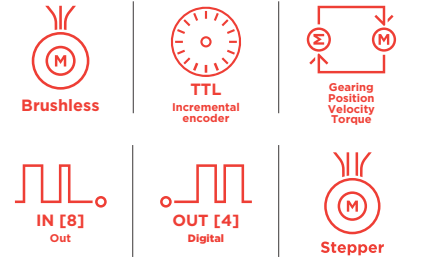
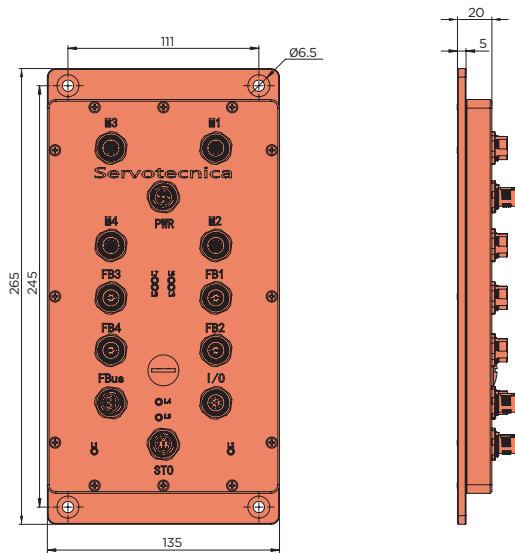

IO-Link

Values	Unit
<b>Power</b>	
1 Electronic supply voltage Ue	VDC 19..30
2 Power supply voltage Up	VDC 19..60
3 Max. output current	A 10A/axis
4 Continuous output current @ Up=48VVDC	A 5A/axis
5 Output voltage	up to 96%
<b>Motor types</b>	
6 Brushless	yes
7 DC motors	no
8 BLDC motors	yes
9 Stepper motors	yes
<b>Mechanical</b>	
10 Size LxWxH	mm 265x135x20
<b>Communication IO-Link</b>	
11 Protocol	IO-Link
12 Galvanically isolated	yes
<b>Incremental encoder</b>	
13 Input voltage	VDC 0..5
14 Signal type	differential, single ended
<b>Digital input</b>	
15 Number	8 (Din0..7)
<b>Digital output</b>	
16 Number	4 (Dout0..3)
17 Continuous output current	A 0.5 (Load: resistive, inductive)
<b>Environment</b>	
18 Operating temperature	°C 0..50°C

## Connection

M1..M4	BLDC/Brushless	Stepper
1	Temp.Sensor	PT1000
2	Temp.Sensor	PT1000
3	Bk+	Brake +
4	Bk-	Brake -
5	Mb	Motor phase B
6	N.C.	Non Connected
7	Ma	Motor phase A
8	Mc	Motor phase C
<b>FB1..FB4 Feedback</b>		
1	+U5V	5V output voltage for sensor supply
2	A	Inc. encoder, A channel
3	/A	Inc. encoder, A channel inverted
4	B	Inc. encoder, B channel
5	/B	Inc. encoder, B channel inverted
6	Inx	Inc. encoder, index channel
7	/Inx	Inc. encoder, index channel inverted
8	GND	Ground for sensor supplychannel inverted
<b>STO Logic power supply / STO</b>		
1	+Ue24V	Electronic supply voltage
2	GND	Ground for electronic supply voltage
3	N.C.	Non Connected
4	FE	Functional earth
5	STO1	Safety Torque Off 2 +24Vdc
6	STO2	Safety Torque Off 1 +24Vdc
7	STO Com	Safety Torque Com
8	STO Out	Safety Torque Off Output
<b>Fbus IO-Link</b>		
1	Vplus	Vplus
2	N.C.	Non Connected
3	N.C.	Non Connected
4	CQ	CQ
5	N.C.	Non Connected
<b>I/O Digital I/O</b>		
1	Din5	Digital Input 5
2	Din3	Digital Input 3
3	Din2	Digital Input 2
4	Din0	Digital Input 0
5	Dout0	Digital Output 0
6	Dout1	Digital Output 1
7	Dout2	Digital Output 2
8	Dout3	Digital Output 3
9	Din6	Digital Input 6
10	Din4	Digital Input 4
11	Din1	Digital Input 1
12	Din8	Digital Input 8
<b>PWR Power supply</b>		
1	+Up	Power supply voltage
2	+Up	Power supply voltage
3	GND	Ground for power supply voltage
4	GND	Ground for power supply voltage